

Supplement to the methodology for risk
evaluation of biocides
**Harmonisation of
Environmental Emission
Scenarios for Slimicides.
(product type 12)**

European Commission DG ENV / RIVM

September 2003

EUBEES



This report has been developed in the context of the EU project entitled "Gathering, review and development of environmental emission scenarios for biocides" (EUBEES 2).

The contents have been discussed and agreed by the EUBEES 2 working group, consisting of representatives of some Member States, CEFIC and Commission. The Commission's financial support of the project is gratefully acknowledged (Ref. B43040/2001/326154/MAR/C3).

Barbarossastraat 35
Postbus 151
Nijmegen 6500 AD
The Netherlands
+31 (0)24 328 42 84 Telephone
+31 (0)24 322 81 70 Fax
info@nijmegen.royalhaskoning.com E-mail
www.royalhaskoning.com Internet
Amhem 09122561 CoC

Document title Harmonisation of Environmental Emission
Scenarios
Biocides: PT 12 – Slimicides

Status

Date 16 September 2003
Project name Environmental Emission Scenarios for Biocides
Project number 4L1784.A0
Client European Commission DG ENV / RIVM
Reference 4L1784.A0/R0009/FBA/TL/Nijm

Drafted by Eefje van der Aa and Froukje Balk
Checked by Froukje Balk
Date/initials check
Approved by
Date/initials approval

FOREWORD

The European Parliament and the Council adopted in 1998 the Directive 98/8/EC on the placing of biocidal products on the market (Biocidal Products Directive, BPD). The background for the directive is a need for harmonisation of the legislation of the Member States regarding this type of chemicals, which are intended for exerting a controlling effect on higher or lower organisms. The Directive requires an authorisation process for biocidal products containing active substances listed in positive lists (Annex I and IA). Active substances may be added to the positive lists after evaluation of the risks to workers handling biocides, risks to the general public and risks to the environment. The risk assessments are carried out for the life cycle of the biocide: risks during and resulting from the application, risks associated with (the use of) the treated product and risks resulting from the disposal of the biocide and the treated product.

For the environmental risk assessment the environmental exposure needs to be assessed. As a tool in this assessment emission scenarios are developed specific for the Product Types distinguished in the Directive. This report gives a description of emission scenarios for Product Type 12, Slimeicides.

This report has been developed by Royal Haskoning, The Netherlands, in the context of the EU project entitled "Gathering, review and development of environmental emission scenarios for biocides" (EUBEES 2). The contents have been discussed and agreed by the EUBEES 2 working group, consisting of representatives of some Member States, CEFIC and Commission. The Commission's financial support of the project is gratefully acknowledged (Ref. B4-3040/2001/326154/MAR/C3).

SUMMARY

The European Parliament and the Council adopted in 1998 the Directive 98/8/EC on the placing of biocidal products on the market (Biocidal Products Directive). As an implication an environmental risk assessment is to be carried out. For this purpose a uniform method to predict the potential environmental emissions needs to be available. Therefore emission scenario documents are being developed for the various biocidal product types. This report deals with product type 12, Slimicides.

The methods of estimating the emission rate of slimicides to the primary receiving environmental compartments are described. According to Annex VI of the Biocidal Products Directive the risk assessment shall cover the proposed normal use of the biocidal product (typical case scenario) together with a 'realistic worst case scenario'. Therefore two harmonised emission scenarios were selected. The calculation of a realistic worst case PEC using environmental interactions, for example subsequent movement of emissions to secondary environmental compartments (e.g. from water to sediment), is considered to be subject to fate and behaviour calculations and models, and outside the scope of the Guideline.

This report is based on:

- three existing emission scenarios for slimicides in papermaking processes and a scenario for slimicides used in oil industry produced in different EU countries;
- discussions in the working group for the EU project "Gathering, review and development of environmental emission scenarios for biocides (EUBEES 2)";
- and data supplied by some Member States.

The three emission scenarios with respect to papermaking processes are:

- The RIVM/FEI-scenario: developed by the Finnish Environment Institute and the Dutch Institute of Public Health and the Environment (2002);
- The SNCI-scenario: developed by the Swedish National Chemicals Inspectorate (1995);
- The USES-scenario: developed by Luttkik et al. (1993).

These scenarios were compared and integrated where possible to produce a harmonised, typical case scenario and a harmonised, realistic worst case emission scenario for slimicides used in papermaking processes. Calculations were carried out for some substances representing different physical-chemical and environmental behaviour to compare the results of the various scenarios.

The emission scenario with respect to the oil industry is the CHARM-scenario. This scenario was developed in close co-operation between the exploration and production industry, chemical suppliers and authorities of some of the countries party to the Oslo and Paris conventions (2001). In this report the suitability of the CHARM-scenario for risk evaluation in the EU was checked.

Conclusions

Paper-industry

After considering the analyses carried out in this report, the RIVM/FEI-scenario for a paper mill with chemical mechanical treatment of the waste water is considered to be a realistic worst case scenario. In contrast with the USES-scenario this scenario considers hydrolysis in the paper mill. According to the calculations in section 4.5

hydrolysis may be important for certain slimicides. Furthermore, the RIVM/FEI-scenario assumes by default (and a realistic worst case situation) that:

- both the short and long circulation water are treated with slimicide,
- and there is no connection to a pulp mill.

However the possibility exists to change these default parameters.

The predicted concentration in the receiving surface water for the RIVM/FEI-scenario with mechanical/chemical treatment gives the highest concentrations compared to the other scenarios of RIVM/FEI and to USES, because this scenario has the shortest retention time in the entire process.

The predicted concentration in the effluent for the RIVM/FEI-scenario for a paper mill with chemical and mechanical treatment may be somewhat lower when adsorption to paper particles and sheets in the paper mill is taken into account. According to calculations with USES emissions to sludge (in an STP) are important in case of more lipophilic chemicals. Emissions to air can be considered negligible.

Biodegradation in paper mill processes as described in the RIVM/FEI-scenario is questionable. No appropriate data are available to calculate it. Therefore it is proposed to leave it out.

The SNCI-scenario is considered not suitable to use as a method to predict emissions of slimicides from paper mills.

Based on these conclusions it is recommended to perform risk assessments for slimicides in papermaking mills with the following scenarios.

- A reasonable worst case scenario:
The RIVM/FEI-scenario for a paper mill with primary clarifier and chemical and mechanical treatment;
- A typical scenario:
The RIVM/FEI-scenario with primary clarifier and treatment in a WWTP (calculated with Simple Treat, TGD (EC2003B)).

This provides the possibility that certain slimicides only may be approved for use in paper mills that discharge their wastewater into a WWTP.

For the discharges of wastewater from paper mills into marine waters and estuaries the TGD (EC2003B) assumes chemical/mechanical treatment for industrial discharges in coastal waters. Furthermore it is assumed that these discharges are diluted by a factor 100. Therefore the RIVM/FEI-scenario for a paper mill with primary clarifier and chemical/mechanical treatment can be used with a dilution factor of 100 for discharge into coastal waters.

It should be taken into account that, due to variable use patterns of paper mill slimicides, it is necessary to consider the proposed instructions for use and make where relevant, separate calculations for continuous use, shock dose, etc, to cover all realistic worst case dosage patterns. In case of shock treatment it must be considered that the concentration in the water will not be levelled off much in the WWTP.

To prevent confusion with respect to Emission Scenario Documents (ESDs) for several chemicals (including biocides) used in the paper industry, a description of the existing ESDs is given below.

There are three emission scenario documents that relate to the paper industry:

- ESD for chemicals used in pulp, paper and board industry:
This document relates to the chemicals industry category 12 and can be used for industrial chemicals used in the pulp, paper and board industry (IC12 in TGD (EC2003A));
- ESD for biocides in paper coating and finishing (BPT 6, 7 & 9 in TGD (EC2003B)):
This ESD should be used when dealing with biocides used as preservatives in paper coating and finishing (PT6, 7 and 9).
- ESD for biocides used in the paper and cardboard industry (PT12 slimicides):
This ESD (recommended in this report) should be used for biocides used as slimicides in the paper and board industry.

Oil-industry

The TGD [EC2003] allows for the use of more precise information in 'site specific' assessments. For substances released from offshore platforms it is noted that 'a harmonised mandatory control system for the use and reduction of the discharge of offshore chemicals is already agreed within OSPAR (OSPAR 2000a, 2000b). For this specific exposure situation within the EU legislation, the methodology proposed by OSPAR can be taken into consideration'. It is added that 'the methodology for assessing releases from platforms (e.g. CHARM-model) that has been developed in the context of these OSPAR decisions was not re-discussed in the context of the development of the present guidance document for marine risk assessment.'

The EUBEES working group considers the emission estimations according to the CHARM method to be applicable for the estimation of emissions of slimicides from oil platforms. Several parameters of the assessment of environmental distribution (eg. dimensions of the receiving compartment) were discussed and they may be reviewed in a later stage on the basis of relevant data and evaluations. In the mean time this assessment can also be done according to the CHARM method.

Readers guide to this document

This document is divided in two sections. The first section considers slimicides in the paper production processes, the second section considers slimicides used in the oil industry. The description of the original scenarios is presented in appendix 1.

Paper-industry

A general description of the paper production process is presented in chapter 2. The identification of the application points and the potential points of release for slimicides used in paper production processes are described in chapter 3.

For the emission of biocides from paper production processes, various scenarios were found that are described in section 4.1 of this document. These scenarios were analysed and evaluated in sections 4.2, 4.3 and 4.4, using uniform symbols and standard formats. In section 4.5 the different scenarios were compared by elaborating calculations.

Finally, in chapter 5 a proposal is made for emission scenarios for a paper mill with chemical and mechanical treatment and a paper mill with an on-site WWTP.

For quick reference, the proposed scenarios are presented below.

In Figure A the recommended scenarios are described from paper mill up to the concentration in the primary receiving compartments. For the reasonable worst case scenario this is the concentration in surface water, for the typical case this is the influent concentration in an industrial wastewater treatment plant (WWTP).

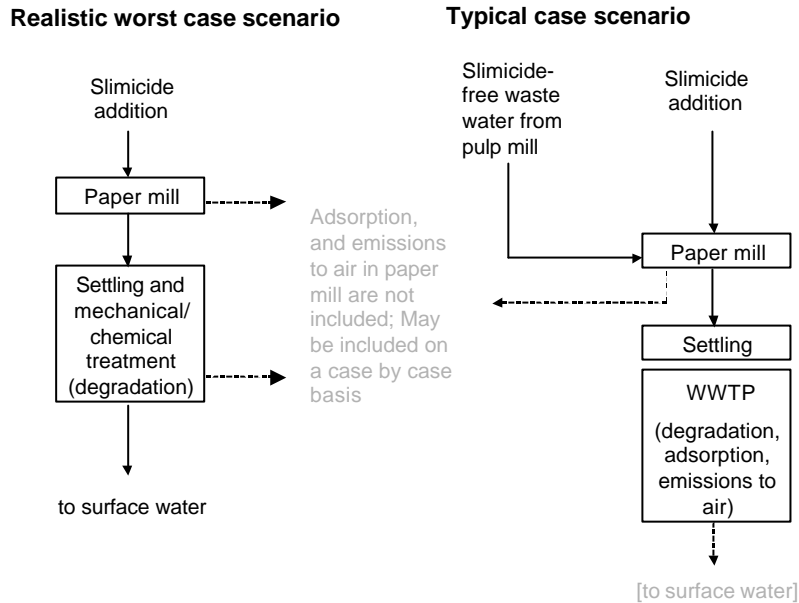

Figure A Realistic worst case scenario and typical case scenario for slimicides used in paper production processes

The tables A, B and C contain the necessary input parameters and calculations for the recommended typical and worst case scenario under various pH conditions in the paper making process. Different calculations may be carried out for shock dosing and more frequent intermittent or continuous dosing.

Table A Common part of the models for the calculation of the theoretical average concentration (i.e. not including degradation) before wastewater treatment, depending on the way the dosage is expressed in the user's instructions:
 [A] amount of biocide per tonne of product and
 [B/C] amount of biocide per m³ of water at the wire part of the paper machine.
 (modified from RIVM/FEI-scenario).

Variable/parameter	Unit	Symbol	Value	S/D/O/P
Input				
[A]				
Amount of biocidal product per tonne of dry paper according to user's instructions	[kg. tonne ⁻¹]	Q _{prod}		S
Amount of wastewater per tonne of dry paper	[m ³ . tonne ⁻¹]	WW	15	D
[B]				
Amount of biocidal product according to user's instructions	[kg.m ⁻³]	Q _{prod}		S
[A/B]				
Fraction of active ingredient in biocide preparation	[-]	F _{ai}		S
[B/C]				
Treatment of both long and short circulation with slimicide	[-]	APPL	yes or no	
Slimicide bearing fraction of the total wastewater flow coming from the short circulation of the wire part	[-]	F _{ww1}	APPL	
Typical case			yes: 0.6	P
Reasonable worst case			no: 1.0	P
Connection to pulp mill	[-]	CONN	yes or no	
Fraction dilution of slimicide-free wastewater with wastewater from pulping	[-]	F _{ww2}	CONN	
Typical case			yes: 0.5	P
Reasonable worst case			no: 0	P
[C]				
Concentration according to user's instructions	[g.m ⁻³]	C _{prod}		S
[A/B/C]				
Fraction of the slimicide that evaporates to air in the dry end of the papermaking machine	[-]	F _{air, paper}		S
Fraction adsorbed to the paper sheets in the dry end of the papermaking machine	[-]	F _{ads, paper}		S
OR: Total fraction of the slimicide lost in the dry end of the papermaking machine	[-]	F _{total loss, paper}	0.1	D
Output				
Dose of a.i. dependent on specifications for the amount of biocide preparation (Q _{prod})	see calculations	DOSE _{ai}		

Variable/parameter	Unit	Symbol	Value	S/D/O/P
Theoretical concentration (i.e. assuming no degradation) before wastewater treatment (kg.m ⁻³)	[g.m ⁻³]	C _{paper}		

Calculations¹⁾

$$F_{\text{total loss, paper}} = F_{\text{air, paper}} + F_{\text{ads, paper}} \text{ or default}$$

$$[A] \text{ DOSE}_{\text{ai}} = Q_{\text{prod}} * F_{\text{ai}}$$

$$C_{\text{paper}} = \text{DOSE}_{\text{ai}} / \text{WW} * 1000 * (1 - F_{\text{total loss paper}})$$

Unit

[-]

 [kg. tonne of paper⁻¹]

 [g. m³]

$$[B] \text{ DOSE}_{\text{ai}} = Q_{\text{prod}} * F_{\text{ai}}$$

 [kg. m³ at the wire part]

$$C_{\text{paper}} = \text{DOSE}_{\text{ai}} * F_{\text{ww1}} * (1 - F_{\text{ww2}}) * 1000 * (1 - F_{\text{total loss, paper}})$$

 [g. m³]

$$[C] \text{ } C_{\text{paper}} = C_{\text{prod}} * F_{\text{ww1}} * (1 - F_{\text{ww2}}) * (1 - F_{\text{total loss, paper}})$$

 [g. m³]

1) Table A does not have the possibility of input for all dosages that might be found in the user's instructions. However the data can be converted easily using the calculations as presented in Table 4.2

Table B Common part for the emission scenarios for calculating the release of slimicides in paper mills taking degradation into account (modified from RIVM/FEI -scenario). Degradation includes hydrolysis during the papermaking process as well as during water treatment; biodegradation may occur during water treatment; other degradation processes are not excluded. Different pHs in the process may be taken into account.

Variable/parameter	Unit	Symbol	Value	S/D/O/P
Input				
Half-life for degradation during paper production process	[d]	DT50deg1		S
Half-life for degradation during settling and chemical/ mechanical water treatment	[d]	DT50deg2		S
Output				
Rate constant for hydrolysis under different process conditions (pH ~5, pH~7, pH~8)	[d ⁻¹]	kdeg1		
Rate constant for degradation during water treatment (hydrolysis and biodegradation)	[d ⁻¹]	kdeg2		
Calculations				
General form:				
$kdeg = \ln 2 / DT50$				

Table C Model for the calculation of the relevant effluent concentrations. Concentration reductions are due to degradation in process water and during water treatment (see figure A) (modified from RIVM/FEI-scenario)

Variable/parameter	Unit	Symbol	Value	S/D/O/P
Input				
Theoretical concentration of a.i.	[g.m ⁻³]	C _{paper}		O
Hydraulic retention time for paper making process	[d]	T _{pr}	0.167	D
Hydraulic retention time for primary settling and chemical/mechanical treatment	[d]	T _{treat}	0.167	D
Time elapsed since dosing event	[d]	t		S
Time interval between dosing	[d]	T _{int}		S
Fraction of the slimicide adsorbed to particles during primary settling	[-]	F _{ads, settling}	0	D
Fraction of the slimicide adsorbed to particles during chemical and mechanical treatment	[-]	F _{ads, cm}	0	D
Output				
Concentration in influent to the primary settler (various conditions)	[mg. l ⁻¹]	C _{infl-ps}		
Concentration in effluent of water treatment system	[mg. l ⁻¹]	C _{local} _{effl-treat}		
Concentration in influent to WWTP	[mg. l ⁻¹]	C _{local} _{infl-WWTP}		

Calculations for the reasonable worst case scenario:

[A] (Semi-)continuous dosing

$$C_{\text{infl-ps}} = C_{\text{paper}} / (1 + k_{\text{deg1}} * T_{\text{pr}})$$

[B] and [C] Shock dose or intermittent dosing

after one dosing

$$C_{\text{infl-ps}} = C_{\text{paper}} * e^{-k_{\text{deg1}} * t}$$

after n dosings at intervals of T_{int}

$$C_{\text{infl-ps}} = \sum_{i=1}^n C_{\text{paper}} * e^{-(t - (i-1) * T_{\text{int}}) * k_{\text{deg1}}} \quad \text{for } (t - (i-1) * T_{\text{int}}) > 0$$

$$C_{\text{local}}_{\text{effl-treat}} = C_{\text{infl-ps}} * (1 - F_{\text{ads, settling}} - F_{\text{ads, cm}}) * e^{-k_{\text{deg2}} * T_{\text{treat}}}$$

Calculations for the typical case scenario:

$$C_{\text{local}}_{\text{infl-WWTP}} = C_{\text{paper}} * (1 - F_{\text{ads, settling}}) * e^{-k_{\text{deg1}} * T_{\text{pr}}}$$

Oil-industry

A general description of the oil production process is presented in section 6.1. The identification of the application points and the potential points of release for slimicides used in oil production processes are described in section 6.2.

For the emission of biocides from oil production processes, the CHARM-scenario was found. This scenario is described in section 6.3.1 of this document. The scenario is analysed and evaluated in sections 6.3.2 and 6.3.3.

Finally, in section 6.3.4 the conclusions with respect to the CHARM-scenario are found.

Table D describes the harmonised CHARM-scenario.

Table D Emission scenario for calculating the releases from slimicides used in oil drilling processes (CHARM2001)

Variable/parameter	Unit	Symbol	Value	S/D/O/P
Input				
[A]				
Fraction of the a.i. in the mud	[-]	F _{ai,mud}		S
Density of the discharged mud	[kg.m ⁻³]	RHO _{mud}	Section ¹⁾ 17.5": 1400 12.25": 1600 8.5": 1600	D
[B]				
Dosage of the a.i. in the mud	[pounds per barrel]	DOSE _{ai,mud}		S
Conversion constant from pounds per barrel to kg/m ⁻³	[-]	F _{conv}	2.85	D ^c
[A/B]				
Volume of mud discharged for specific section	[m ³]	V _{mud, discharged}	Continuous Section ¹⁾ 17.5": 600 12.25": 450 8.5": 250 Batchwise Section: 12.25": 375 8.5": 280	D
Number of platforms per square kilometre	[km ⁻²]	N _{platform}	0.1	D
Average water depth around the platform	[m]	Depth _{local _wway}	150	D
Fraction of sea water refreshed in the receiving volume around the platform per day	[d ⁻¹]	F _{repl,water}	0.24	D
Time needed to drill a section	[d]	T _{drilling}	16	D
Dilution factor for batchwise discharges (selected default)	[-]	DILUTION _{batch}	13000	D

Variable/parameter	Unit	Symbol	Value	S/D/O/P
Sediment-water partition coefficient	[l.kg ⁻¹]	Kp		S
Fraction of a substance in sediment that is degraded in 1 year	[-]	Fdegrad		S

Output:

Amount of a.i. discharged	[kg]	E _{ai,discharged}
Volume of ambient water per platform available as diluent	[m ³]	V _{water,platform}
Volume of water passing the platform	[m ³ .d ⁻¹]	Q _{repl,water}
Predicted Environmental Concentration in marine water for continuous discharges of a.i. in WBM	[mg.l ⁻¹]	PEC _{water,cont}
Predicted Environmental Concentration in marine water for batchwise discharges of a.i. in WBM	[mg.l ⁻¹]	PEC _{water,batch}
Predicted Environmental Concentration in marine sediment for continuous discharges of a.i. in WBM	[mg.kg ⁻¹]	PEC _{sediment,cont.}

Intermediate calculations:

Amount of a.i. discharged (kg):

[A]

$$E_{ai,discharged} = F_{ai,mud} * V_{mud,discharged} * RHO_{mud}$$

[B]

$$E_{ai,discharged} = DOSE_{ai,mud} * V_{mud,discharged} * F_{conv.}$$

Volume of ambient water per platform available as diluent (m³)

$$V_{water,platform} = 1/ N_{platform} * Depth_{local_wway} * 10^6$$

Volume of water passing the platform (m³.d⁻¹)

$$Q_{repl,water} = V_{water,platform} * F_{repl,water}$$

End calculations:

$$PEC_{water,cont} = (E_{ai,discharged} / (T_{drilling} * Q_{repl,water})) * 10^3$$

$$PEC_{water,batch} = (E_{ai,discharged} / V_{mud,discharged}) / DILUTION_{batch} * 10^3$$

$$PEC_{sediment} = PEC_{water,cont.} * Kp * (1 - Fdegrad)$$

- 1) The drilling well is divided in different drilling sections (vertical division). Every section equals a layer of soil or rock with specific characteristics. The diameter of the section is shown in inches (").

CONTENTS

	Page
1 INTRODUCTION	1
1.1 Sources of information for product type 12 (Slimicides)	1
2 PAPER INDUSTRY: DESCRIPTION OF INDUSTRY OR USE AREA	4
3 IDENTIFICATION OF THE APPLICATION AND POTENTIAL POINTS OF RELEASE FOR SLIMICIDES USED IN PAPER PRODUCTION PROCESSES	5
4 EMISSION SCENARIOS FOR SLIMICIDES IN PAPER PRODUCTION PROCESSES	7
4.1 Description of available scenarios for slimicides used in paper making processes	7
4.1.1 RIVM/FEI-scenario	7
4.1.2 SNCI-scenario	10
4.1.3 USES-scenario	12
4.2 Comparison of scenarios	17
4.2.1 Dimensions of the paper mills and WWTPs	17
4.2.2 The amount of water per tonne of produced paper	18
4.2.3 Retention times	18
4.2.4 Wastewater treatment	19
4.2.5 Other emission routes	19
4.2.6 Degradation	20
4.2.7 Discharge into receiving surface waters	20
4.3 Overview of methods	21
4.3.1 RIVM/FEI	21
4.3.2 SNCI	28
4.3.3 USES 3.0	31
4.4 Qualitative comparison of the methods	31
4.4.1 Calculation of emissions	32
4.4.2 Calculation of the environmental concentration in the compartments surface water, sludge and air	33
4.5 Detection of similarities and differences, comparison and examples	33
5 DISCUSSION ON SLIMICIDES IN PAPER PRODUCTION PROCESSES	37
5.1 Dimensions and characteristics of the point sources (including on site waste water treatment plants) and receiving environmental compartments	37
5.2 Degradation	38
5.3 Formulation of the elimination processes	38
5.4 Conclusions	39
5.5 Recommendation	39
6 OIL INDUSTRY	45
6.1 Description of industry or use area	45

6.2	Identification of the points of application and release for slimicides used by the oil extraction industry	45	
6.3	Emission scenario for SLIMICIDES IN OIL EXTRACTION PROCESSES	46	
6.3.1	Description of available scenario for slimicides used in oil extraction processes	46	
6.3.2	Overview of method	47	Deleted: 48
6.3.3	Discussion of the method	47	Deleted: 49
6.3.4	Conclusion	47	Deleted: 52
7	REFERENCES	47	Deleted: 53

Appendix 1: Original descriptions of methods
 Appendix 2: Calculation results

1 INTRODUCTION

Product type 12 (slimicides) are biocides used to control slime-producing micro-organisms in industrial processes where substrates are handled. The main industries are:

- slimicides used in the paper production industry;
- slimicides used during oil extraction.

For slimicides used in the paper production industry three emission scenarios have been described. These are compared and integrated where possible to produce one harmonised emission scenario. The methods of estimating the emission rate of slimicides to the primary receiving environmental compartments are described. According to Annex VI of the Biocidal Products Directive the risk assessment shall cover the proposed normal use of the biocidal product together with a 'realistic worst case scenario'. Therefore two harmonised emission scenarios were selected. The calculation of a realistic worst case PEC using environmental interactions, for example subsequent movement of emissions to secondary environmental compartments (e.g. from water to air), is considered to be subject to fate and behaviour calculations and models, and outside the scope of the Guideline.

For slimicides used by oil extraction only one existing scenario was available. This scenario is discussed and adapted as far as possible to the standard format.

The report is based on:

- three emission scenarios for paper production processes produced in different EU countries;
- one scenario for slimicides used by oil extraction;
- discussions in the working group for the EU project "Gathering, review and development of environmental emission scenarios for biocides (EUBEES 2)".

In this report, the emission scenarios are presented in text and tables. In the tables, the input and output data and calculations are specified, and units according to USES are used. The input and output data are divided into four groups:

- S data Set parameter must be present in the input data set for the calculation to be executed (no method has been implemented in the system to estimate this parameter; no default value is set, data either to be supplied by the notifier or available in the literature);
- D Default parameter has a standard value that is used by default (these defaults can be changed by the user);
- D^c Default parameter has a standard value that cannot be changed by the user;
- O Output parameter is the output from another calculation (most output parameters can be overwritten by the user with alternative data);
- P Pick list parameter values to be chosen from a pick list with values.

1.1 Sources of information for product type 12 (Slimicides)

The following documents are the main sources of information for the present document:

1. National Institute of Public Health and the Environment (RIVM), Finnish environment Institute (FEI): Emission Scenario Document for biocidal products applied in the paper and cardboard industry (draft, 2002) **Code: RIVM2001**
Emission scenario with the focus on slimicides intended for use in paper and cardboard manufacturing industries.
2. National Chemicals Inspectorate, Sweden, Eriksson, U., A. Johnson, M. Törnlund: Risk Assessment of Slimicides (1995) **Code: SNCI1995**
A comparison between different slimicidal active ingredients, with the help of calculations of Predicted Environmental Concentrations according to three different scenarios.
3. Institute for Environmental Research (INFU), University of Dortmund, UBA Berlin: Gathering and review of Environmental Emission Scenarios for biocides (2000) **Code: INFU2000**
This report gives general information about the use of slimicides in papermaking and oil industries. The scenario from USES is also described in this report.
4. User guide for the evaluation of chemicals used and discharged offshore version 1.2: A CIN revised charm III report 2001: Henriquez, L.R., C.C. Karman, M. Robson, M. Thatcher
Code: CHARM2001
This report contains a model for calculating the PEC:PNEC ratios with the objective to rank chemicals on the basis of these ratios. This model can also be used to calculate the PEC in the receiving environmental compartment for oil and gas production.
5. COWI and CETOX: Biocide Use in Denmark Phase 2, Preliminary Assessment of Human and Environmental Exposure (2001) **Code: COWI2001**
This report contains an estimate of the consumption of offshore slimicide and release estimates and general information on the oil production process.
6. OECD Environmental Health and Safety Publications: Emission scenario document on water treatment chemicals (2002), Environment Directorate, Organisation for Economic Co-operation and Development **Code: OECD2002**
This draft-document contains general information on papermaking processes based on the situation in the UK. In some areas wider information on Europe has been included. The data were gathered mostly in the period 1994-1997. The report provides information on the amount of biocide used and the releases of the substances.
7. European Commission: Technical Guidance Document (TGD) in support of Commission Directive 93/67/EEC on risk assessment for new notified substances and commission regulation (EC) No. 1488/94 on risk assessment for existing substances and directive 98/8/EC of the European parliament and of the council concerning the placing of biocidal products on the market part IV (2003) **Code: EC2003**
This report contains an emission scenario for industrial chemicals used in the pulp, paper and board industry. As well as slimicides, other kinds of biocides are used in papermaking processes, e.g. pulp preservatives and coating additives, such as film preservatives (PT 6) and in-can preservatives (PT 7). When reading

the TDG(1996). Although not specifically developed for biocides this scenario could be used to calculate emissions caused by slimicides, but it is quite robust for that. Therefore this TGD emission scenario has not been included in this report.

Code: EC2003B

Next to the previous scenario this report contains an emission scenario for biocides used in paper coating and finishing and was consulted for general information on the papermaking process.

The report is developed during EUBEES I (C. Tissier and V. Migné, INERIS) The report provides, among others, information on the amount of biocides used and the release of these substances.

9. Finnish Environment Institut, Sirkka, S., Environmental exposure assessment of slimicides (2001) **Code: SIRKKA2001**

10. Paper-mill model for slimicides, D. Baur of Rohm and Haas Company. **Code: Baur 2002.**
This is a spreadsheet including formula and defaults. This model has not been included in this report.

11. Crechum Technologies Inc: Chemical releases from Canadian Pulp and Paper Mills, Draft report (2003) Code: CAN2003.
This report presents an evaluation of chemical releases from the Canadian pulp and paper industry in support of the assessment of new substances carried out at Environment Canada. The method employed is based on release scenarios and chemical usage data obtained for the Canadian industry. The study is primarily focused on release estimates of specialty and bleaching chemicals used at kraft pulp mills, non-integrated paper mills and recovered paper mills. The results provide conservative release estimates for the Canadian industry. Data with respect to slimicides are not included due to lack of data.

2 PAPER INDUSTRY: DESCRIPTION OF INDUSTRY OR USE AREA

In the past water in the paper industry was used on a once-through basis at the rate of about 50 m³ per tonne of product (OECD2002). In recent years the industry has invested considerably in procedures to recycle water by closing up the paper mill water system. Because of this, and because of the fact that the materials used in the paper industry offer a favourable environment for the growth of microorganisms, it has become necessary to use biocides to prevent problems with microbiological growth in the water system.

Microorganisms can be harmful by producing slime, which can interfere with the production process. Each paper pulp creates its own specific environment and therefore biocidal treatment of slime is very difficult. A variety of active substances are used. The main function of the slimicides is to suppress the growth of the microorganisms. This can be achieved by a continuous supply of a slimicide or by a single defouling or repeated slug treatment with elevated doses. Good housekeeping supports these measures. Slimicides used in the paper industry include aldehydes, phenol derivatives, heterocyclic N, S compounds, thiocarbamates and thiocyanates (Source: Baumann et al., 1993 in INFU2000). In table 2.1 several biocides used as slimicides in papermaking industry are given. A list of active substances currently notified for PT 12 under the Second Review Regulation according to the BPD can be found on the ECB Website: <http://ecb.jrc.it/biocides/>.

Table 2.1 Examples of chemicals used as slimicides in papermaking industry

Slimicides
Sodium bromide
Bromochlorodimethylhydantoin (BCDMH)
2-Bromo-2-nitropropane-1,3-diol (BNPD)
5,5-Dichloro-2,2-dihydroxydiphenylmethane
Methylene bis thiocyanate
Quaternary ammonium compounds and polyquaternary ammonium compounds
Bromonitrostyrene
Glutaraldehyde
5-chloro-2-methyl-4-isothiazolin-3-one, 2-methyl-4-isothiazolin-3-one
Sodium dimethyldithiocarbamate, disodium ethylene bis dithiocarbamate
Dodecylguanadine hydrochloride
Dibromonitri lopropionamide
Bis (trichloromethyl) sulphone
2-(Thiocyanomethylthio) benzothiazole
3,5 Dimethyl-tetrahydro-1,3,5-2H-thiadiazine-2-thione

(Source: OECD2002)

3 IDENTIFICATION OF THE APPLICATION AND POTENTIAL POINTS OF RELEASE FOR SLIMICIDES USED IN PAPER PRODUCTION PROCESSES

Substantial quantities of slimicides are lost (emissions) during use, but because of the wide diversity of operations involving these fluids, generalisation is difficult. This section provides an overview of how and where releases can arise.

The life cycle for slimicides in paper production processes is presented in figure 3.1 (Source: OECD2002). This figure is mainly concerned with the area where water recirculation occurs in the papermaking machine, the wire and press section, called the wet-end. Because of the fact that the water is recycled, water treatment is necessary. Therefore slimicides (PT12) are applied at the wet-end.

There are also several other biocides that are used in the paper industry. These are PT6 (in-can preservatives), PT7 (film preservatives) and PT9 (fibre, leather, rubber and polymerised material preservatives). PT6, PT7 and PT9 are applied in the drier section (see figure 3.1) and on recycled fibers and are not considered in this report. During EUBEES I an emission scenario document was produced for these product types by INERIS (Tissier and Migné) that is currently incorporated in the TGD (EC2003B) (see section 1.2).

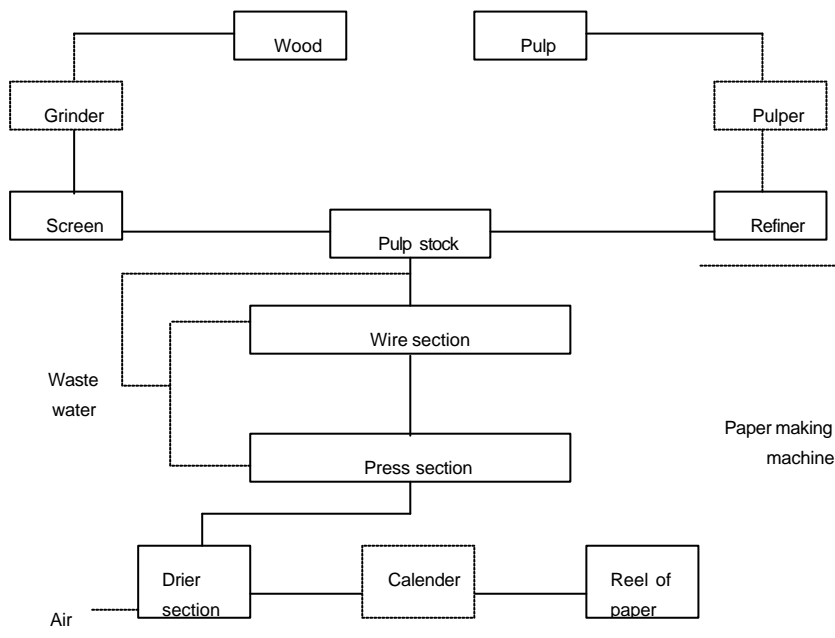

Figure 3.1 Paper making process (Source: OECD2002). for more details see figure 3.1 of the RIVM/FEI -scenario in Appendix 1.

Raw material in the form of wood pulp or waste paper is homogenised at a level of about 1-3% in water. This suspension is first of all distributed on to a continuously moving wire mesh. This allows the fibres to begin the formation of a paper sheet and for much of the water to drain through the mesh.

The next process is for this sheet to pass over a felt where it is rolled to squeeze out more water. These two processes, wire section and press section, are known as the "wet end". The sheet, which now contains 50% water by weight (EC2003B), proceeds over a series of steam heated rotating cylinders, where most of this remaining water evaporates (dry end). The water that evaporates here is only approximately 10% of the total water consumption and contains little or no particulate matter (TGD (EC2003B)). It is not clear which amount of slimicide is adsorbed to the paper sheet and which amount is evaporated with the water.

Next, the paper sheet is passed through a series of polished, close-stacked metal rollers known as a "calender". The sheet is pressed between heavy rollers in the calender which reduces the thickness of the paper and creates a smooth surface. Finally the sheet is rolled onto a long reel, called a log, and removed from the papermaking machine for storage.

During this process, chemicals are added to fulfil a variety of functions. Some of these chemicals are used to give specific properties to the finished product, e.g. starch, size, fillers, pigments, wet and dry strength additives. These substances are dealt with in an emission scenario document included in the Technical Guidance document (EC2003_ICA). As said earlier only the product group of slimicides, for process water treatment, will be considered.

Losses during use

As described in chapter 2 the industry has invested in procedures to recycle water by closing up the paper mill water system. This has mainly been achieved by placing tanks beneath the wire and felt press section of the process (the wet-end), to collect and recycle the water. Despite the effort to recirculate the water, a large amount of water will still be lost from the wet-end as waste water.

Volatile treatment chemicals may be lost during the paper drying process which follows the wet end. Loss of water through evaporation will be of little consequence for chemical release (TGD (EC2003B)), certainly because most slimicides are highly soluble in water. But because the paper sheet is heated during the drying process, a certain amount of the slimicides may be evaporated. Other losses from the papermaking machine include slimicide emissions arising from periodic defouling treatment of the paper making machine that is carried out once or twice a year.

Waste water treatment

Many paper mills have some sort of water treatment prior to discharge. Effluent treatment consists primarily of sedimentation or a combination of sedimentation and activated sludge treatment.

In most EU countries some sort of wastewater treatment is employed, either on site or at a sewage treatment plant. In the OECD2002 it is suggested that in some countries with extensive coastline (e.g. Greece and Spain), there are significant amounts of untreated paper mill effluent discharged to the coastal waters or estuaries, but no information is presented.

4 EMISSION SCENARIOS FOR SLIMICIDES IN PAPER PRODUCTION PROCESSES

4.1 Description of available scenarios for slimicides used in paper making processes

Scenarios for slimicides used in paper making processes have been developed by:

- the Finnish Environment Institute and RIVM (RIVM/FEI, described in RIVM2002);
- the Swedish National Chemicals Inspectorate (SNCI1995);
- and by Luttik et al. (incorporated in USES).

In this section the available emission scenarios for slimicides in papermaking processes are described and compared. For each scenario a short description is given. To be able to clearly understand and compare the different scenarios they are also presented in tables and pictorial form. The pictures show the emission routes which are considered in the scenario and those that are not considered.

The table contains information on the dimensions of the emission sources from industrial use and wastewater treatment and the nature and dimensions of the receiving compartments.

Information on the calculation methods provided with the original scenarios is given in section 4.3. Emissions to the environment during the production and formulation of slimicides and possible discharges other than those from their intended use and disposal are not considered in these emission scenarios.

4.1.1 RIVM/FEI-scenario

The Finnish Environment Institute developed environmental exposure assessment scenarios for slimicides when it started risk assessment in 1993. The scenarios were based on assumptions and parameters from typical Finnish paper mills in the late 1970s and 1980s (Braunschweiler, 1993a, 1993b). Later, the scenarios were developed in more detail and transformed to MS Excel spreadsheet calculations to be used in the exposure assessments (Seppälä, 1997). In a summary report (FEI, 1999) the equations for the calculations of PECs (Predicted Environmental Concentrations) for two slimicide scenarios together with two Excel files are supplied. Recently, the slimicide scenarios have been updated according to changes in paper making practices (Sirkka, 2001). Nowadays, water circulation systems are more closed and many acid processes have been changed to either neutral or slightly alkaline.

The RIVM/FEI-scenario considers the degradation during the process in the paper mill and during the successive wastewater treatment practices (e.g. FEI, 1999; Sirkka, 2001 in RIVM2002). The scenario deals with three situations for the dosage of the biocide:

- the first situation considers the specification in the user's instructions of the dosage per tonne of dry paper;
- the second the dosage per quantity of process water;
- and the third the concentration to be established in the process water.

In all cases the wastewater initially goes to a primary settling unit, followed by three possible ways of treatment. First, the wastewater may be treated in a WWTP with activated sludge and a secondary settler. Second, there may only be chemical/mechanical treatment. Third, there may be activated sludge treatment with

primary and secondary settlers (named biological treatment), with long retention times. After treatment the effluent is discharged to surface water.

The following types of degradation are taken into account at the successive stages involved (if applicable):

- I PAPER MAKING PROCESS
Biodegradation and degradation due to hydrolysis
- II PRIMARY SETTLING
Biodegradation and degradation due to hydrolysis

TREATMENT:

- IIIa WWTP (Activated sludge, short retention time)
Biodegradation and degradation due to hydrolysis
- IIIb Secondary settling
Biodegradation and degradation due to hydrolysis
- IV CHEMICAL/MECHANICAL
Biodegradation and degradation due to hydrolysis
- V LONG-TERM BIOLOGICAL (including secondary settler)
Biodegradation and degradation due to hydrolysis and photolysis

Typical points of biocide application in the paper making process are the wire pit and shower waters in the short circulation of the wet-end and white water tanks, and broke and pulp storage which belong to the long circulation (Fig. 4.1). The short circulation is the system in which paper machine wire water is separated from the pulp stock in the web forming stage and used for dilution of the thick stock to be delivered to the headbox. The long circulation is the system in which excess process water (white water) from the short circulation and other waters are collected at the paper machine and used for stock dilution and other purposes in stock preparation (Weise *et al.*, 2000). In addition, paper additives (slurries) may also be used, raw water treated and the paper coated or preserved with a biocide but they are not covered by this report. In terms of biocide addition, the worst case situation is a machine with biocide addition at several points in the long circulation as well as in the short circulation. So, it may be assumed that no dilution occurs with the long circulation water, as in many cases biocides are also added to the long circulation water or to the broke system (Sirkka, 2001). This means that 100% of the water coming from the paper machine – both from the short and long circulation water – has been treated with a biocide. In addition, the average number of paper making machines per mill in Finland is about three (Sirkka, 2001). Because of the fact that the dosage of biocides in these machines is independent of each other, it should be considered that all machines have the biocide added simultaneously as the worst case. Therefore, it has been assumed that 100% of the water is treated with the slimicide by default. This is denoted in the model also as F_{ww1} , i.e. the fraction of the total wastewater flow coming from the short and long circulation of the wire part (slimicide bearing wastewater).

Slimicide is degraded to some extent in the process water. On the basis of results from the Finnish paper mill survey the minimum water holding time in the process was 1 - 3 hours for every paper grade, median of all 69 machines was 8 hours and the average 15 hours (Sirikka, 2001). Therefore, the default process water holding time of 4 hours is used for a realistic worst case. Hydrolysis during this period is taken into account in the Finnish model and also some biodegradation. This is because although the process water temperature is typically 40-50 °C in the short circulation of paper making process it normally cools to 30-40 °C before the wastewater treatment plant.

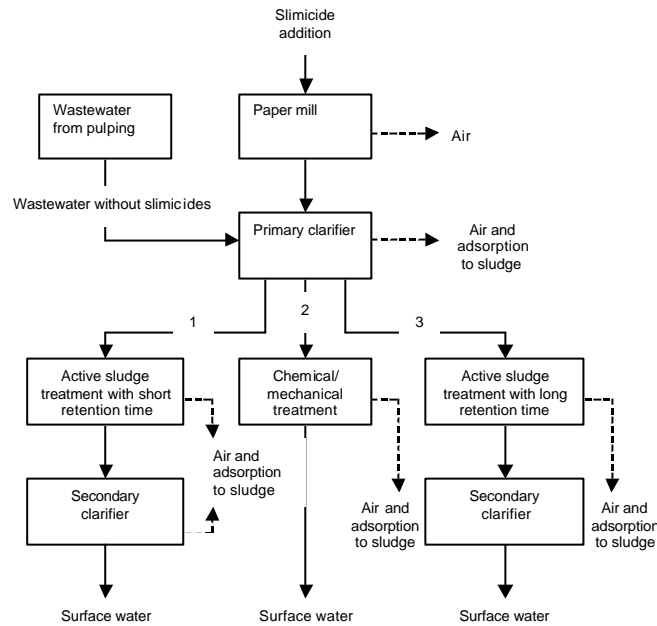

(Source RIVM2002)

Legend:

Route 1 or route 2 or route 3

Not considered in this scenario: -----

Figure 4.1 RIVM/FEI-scenario (Source: RIVM2002 and SIRKKA2001)

Many Finnish paper mills have been integrated with pulp mills – twenty out of the 24 interviewed – and these are likely to have slimicide-free dilution from pulping wastewater to the biocide containing paper machine wastewater; at present this dilution is assumed to be 40-50%. On account of this, the fraction of flow, F_{ww2} , that is dilution water has been introduced into the model. By default no connection to a pulp mill is assumed, i.e. $F_{ww2} = 0\%$; if connection to a pulp mill is considered, F_{ww2} has the default of 50%.

The addition of the biocide may take place continuously, at frequent intervals or by an intermittent shock (defouling) treatment. Defouling treatment is typically done once or twice a year with very high slimicide concentrations (e.g. 200-500 ppm)

which will not be reduced much in the WWTPs. The PECs for such a case should be calculated with a scenario for intermittent emissions. Also for the case of dosing at frequent intervals concentration peaks will occur, which may cause peak concentrations in the wastewater stream as some of the freshly dosed water may be released from the short circulation almost directly. Such peaks will be levelled off when the wastewater reaches a primary settler with a longer residence time. However, it should be noted that the maximum concentration in the effluent would be lower than the initial concentration at discharge when the discharge period is shorter than the retention time of the aeration tank (4 h). This is due to peak dispersion, dilution, and sorption in the sewer system, the primary settler, and the activated sludge process. It is estimated that this maximum concentration will be at least a factor three lower than the initial concentration (according to RIVM2002, this is a typical value based on empirical data). Whether or not this correction factor must be applied needs to be decided on a case-by-case basis. For such short emission periods care must be taken that the emission rates or concentrations are calculated over the actual emission period and not averaged out over one day. It is assumed here that the wastewater coming to the primary settler during the addition of the slimicide is at once completely mixed with the water already present in the basin.

4.1.2 SNCI-scenario

The Swedish National Chemicals Inspectorate (KEMI) has performed calculations of predicted environmental concentrations according to three different scenarios. These scenarios are developed to be able to compare the different slimicidal active ingredients. Scenarios are developed for:

- a fine paper mill;
- a newspaper mill with about 2 days retention time before discharge;
- and a newspaper mill with about 1 day retention time before discharge.

The three scenarios provide default values for the water consumption, the size of the specific paper mill and retention times, temperature and acidity of the process water (see table 4.1). It is assumed that dosage of the process water in the paper mill with slimicides takes place every 12th hour. During 15 minutes a certain amount of slimicide is added to achieve the recommended concentration, during dosing period, in the white water (process water). This recommended concentration is assumed to be found in the user's instructions of the specific slimicide. To calculate the concentration in the effluent of the different wastewater treatment systems first the concentration without degradation is calculated by dividing the total amount of slimicide added to the paper mill in one day by the total water consumption. Next to that the degradation of the slimicide is determined using the half-lives of the slimicide and retention times in the mill and the wastewater treatment installations.

In the calculations the only chemical reaction that is taken into account is hydrolysis. Other chemical and or physical factors, such as adsorption to sludge, may be important. Therefore the calculated values in the effluent according to this scenario could be overestimated. The importance of the chemical/physical reactions is not certain.

A dilution factor of 100 is used to calculate the predicted environmental concentration. There is a great variation in dilution factors. Dilution factors of 10 or less exist in Sweden (1994).

In Sweden there are about 50 paper mills (data from 1994) producing different kinds of paper. Only 40% of them had advanced WWTP containing aerated basin or other types of biological treatment. Therefore scenario 1 might be considered to be the most typical case in Sweden according to SNCI1995. This is concluded from data of 1994. It is not certain whether this conclusion is still appropriate in 2003.

Monitoring studies in different kinds of paper mills with WWTPs often show much lower environmental concentrations (sometimes even a factor 10-100 lower) than calculated from the scenarios.

Possible causes, according to SNCI1995, may be:

- different pH-values: half-lives are very pH dependant
- adsorption to cellulose fibres and particulates
- reaction with nucleophiles in proces and effluent waters
- biotic degradation of the slimicide
- enhanced hydrolysis at higher temperatures

Scenario 1

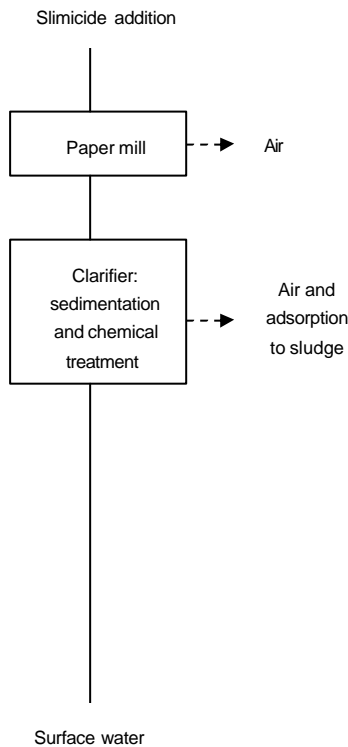

Scenario 2 and 3 (with different retention times for each scenario)

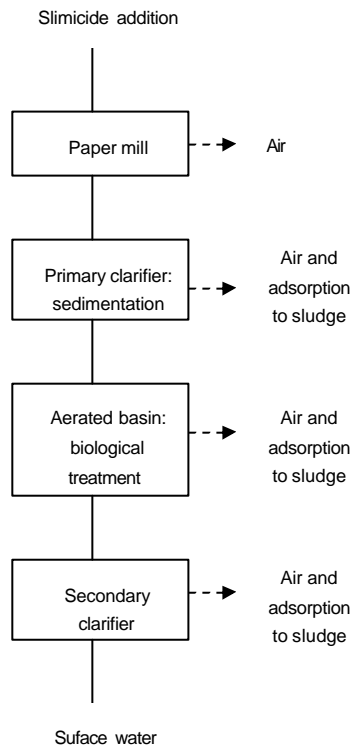

Legend:

Not considered in this scenario: -----

Figure 4.2 SNCI-scenarios (Source: SNCI1995)

4.1.3 USES-scenario

Luttik et al. (1993) present a scenario that was developed for the Netherlands paper and cardboard industry. Default values are supplied for the total water consumption, the capacity of the WWTP and the dilution factor for discharge on surface waters. The production volume lies between 20.000 and 200.000 tons of paper per year. In many cases paper and cardboard producers have their own WWTP. In the scenario an industrial WWTP is used, because the water consumption lies between 800 m³ and 11.000 m³ per day and a standard STP in USES has a capacity of only 2000 m³ per day. The default value of the flow is 3000 m³ per day. For the discharge of waste water to the receiving surface water adapted values for stagnant waters, semi-stagnant waters and large rivers are used. The distribution of the biocide in the WWTP is handled using the standard STP-module of USES with the adapted values for the size of the WWTP and the dilution factor. (Source: INFU2000)

The scenario does not include hydrolysis in the paper mill. During the water treatment process emissions to the receiving surface water, sludge and air are considered.

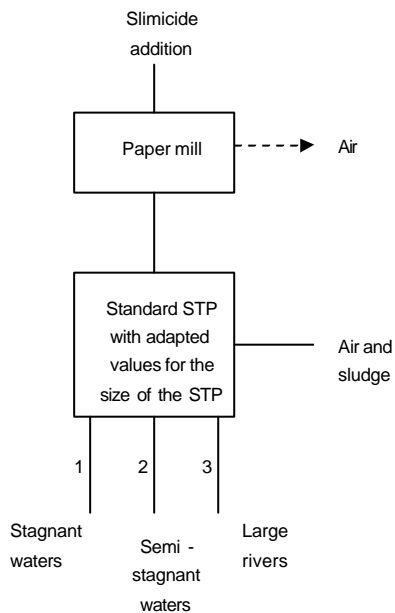

Legend:

Route 1 **or** route 2 **or** route 3

Not considered in this scenario: -----

Figure 4.3 USES-scenario (Source: INFU2000)

Table 4.1 Comparison of scenarios

Original source	Unit	RIVM/FEL	SNCI		USES ¹	
		Paper mill model	Fine paper mill	News-paper mill	News -paper mill	Paper I
Paper mill						
Amount of wastewater for one ton of dry paper	[m ³]	15				
Water consumption per day	[m ³ .d ⁻¹]		5000	25000	28000	3000
Amount of waste water per day	[m ³ .d ⁻¹]		5000	25000	28000	3000
Volume of the white water circuit	[m ³]		300	1000	300	
Dosage		15 minutes every 12th hour to recommended concentration in the white water. The total amount of active ingredient per day is calculated.				
Retention time in the papermill	[h] or [min]	4 h	40 min at 50 °C and pH 4.5	60 min at 50 °C and pH 4.5	20 min at 50 °C and pH 4.5	
Slimicide bearing fraction of the total wastewater flow coming from the short and long circulations	[-]	Treatment of both long and short circulation with slimicide: YES: 100% NO: 60%				
Fraction dilution of slimicide free wastewater from pulping	[-]	Connection to pulp mill: NO: 0% (current default) YES: 50%				
Primary settling						
Retention time for primary clarifier (sedimentation and chemical precipitation)	[h]	4	20 at 35 °C and pH 7	12 at 35 °C and pH 7 (only sedimentation)	5 at 35 °C and pH 7 (only sedimentation)	

Environmental Emission Scenarios (PT12)

Original source	Unit	RIVM/FEI			SNCI		USES ³	
		Paper mill model	Fine paper mill	News-paper mill	News-paper mill	Paper I		
Chemical/mechanical treatment								
Retention time for chemical/mechanical treatment	[h]	4						
Aerated basin/active sludge treatment								
Retention time for the short-term activated sludge unit/aerated basin	[h]	4		20 at 30 °C and pH 7		12 at 30 °C and pH 7		
Capacity of standard STP (USES)	[m ³ .d ⁻¹]						3000 (a)	
Secondary settling								
Retention time for secondary settling	[h]	4		15 at 25 °C and pH 7		5 at 25 °C and pH 7		
Long term biological treatment								
Retention time for long-term biological treatment	[h]	40 (= 12 h primary clarifier + 20 h in activated sludge basin + 8 h secondary setting)						
Receiving environmental compartment: surface water								
Dilution factor for discharge	[-]	10 (default value of USES, not included in	100	100		100		

Environmental Emission Scenarios (PT12)

Original source	Unit	RIVM/FEI	SNCI			USES ³
into surface water		Paper mill model RIVM/FEI model; included however in the RIVM/FEI report)	Fine paper mill	News-paper mill	News -paper mill	Paper ı
Dilution factor for discharge into stagnant waters	[-]					3 (adaç
Dilution factor for discharge into semi-stagnant waters	[-]					10 (ada
Dilution factor for discharge into large rivers	[-]					100 (ac

Environmental Emission Scenarios (PT12)

4.2 Comparison of scenarios

In this section the emission scenarios as described in section 4.1 and the default values in table 4.1 are compared.

4.2.1 Dimensions of the paper mills and WWTPs

The **SNCI-scenarios** describe three clearly defined paper mills with default values for the capacity of the paper mill, the amount of wastewater discharged and the retention times in the mill and the connected WWTP. However it is not clear on what data the scenarios are based. The concentration that is to be established in the white water circuit in the paper mill during the dosing period is used to calculate the concentration in the total amount of water discharged every day.

The **USES-scenario** describes a very simple model with default values only for the amount of wastewater discharged every day. The concentration to be established in the total amount of water that is discharged every day must be known. For the further dimensions of the on site WWTP the values for the standard STP-model of USES are used.

A different approach is taken by the **RIVM/FEI-scenarios**. Depending on the way the dosage of the slimicide is given in the user's instructions, different default values are important. When the dosage is expressed as amount per tonne of paper, the amount of wastewater per tonne of paper is used. The dosage may also be expressed in amount per m³ of water in the paper mill or the concentration to be established in the water. Then it is important to know if only the short circulation or both short and long circulation are treated with slimicide and if the wastewater stream is diluted with slimicide-free water from a connected pulp mill. Short circulation is where the water is separated from the pulp stock in web forming in the wire and press section and used again for stock dilution. Long circulation is the system in which excess water of the short circulation and other waters are collected and used for stock dilution and other purposes in stock preparation. Concerning the question if both short and long circulation are treated with slimicide and if the wastewater stream is diluted with slimicide-free water from a connected pulp mill, a worst case situation would be assuming that no dilution of the concentration in the white water occurs. So, in other words, both short and long circulation are assumed to be treated with slimicide and there is no connection to a pulping mill. The **RIVM/FEI-scenario** includes the choice between these possible situations. There are default values for the sizes of the paper mills, the amount of wastewater that is discharged, and the retention times in the paper mill and connected WWTP sections.

The default values of **USES and SNCI** paper mills are not clearly traceable in the scenario descriptions. The **SNCI-scenarios** assume a dosing frequency of two times a day. Because there is a great variety of paper mills with different capacities, different amounts of wastewater and different dosing methods it is difficult to say which capacity, amount of wastewater or dosing method corresponds to most situations in practice. Therefore it is probably more practical to use the RIVM/FEI-scenario for the calculation of the concentration of the slimicide in the discharged water (assuming that no degradation has occurred yet).

4.2.2 The amount of water per tonne of produced paper

The amount of wastewater per tonne of produced paper depends on the kind of paper mill (different kinds of paper ask for different amounts of water) and the degree of water recycling. The default value used in the **RIVM/FEI scenario** (15 m³/tonne) is based on average data from the Netherlands (Huizinga et al., 1992 and Regoort, 1992 in USES) and Finland (Sirkka2001 in RIVM/FEI2002: The detailed values used in the original Finnish scenarios are about 18 m³/tonne (36.000 m³/d divided by 3670 tonne/d) in the realistic worst case scenario and about 9 m³/tonne (18.000 m³/d divided by 2010 tonne/d) in the typical case scenario, the latter source values being much more variable).

In OECD2002 values between 30-35 m³/tonne are thought to be representative for paper mills in the UK (data from 1994-1997). IPPC2000 (in TGD (EC2003B)) gives the following water releases per tonne of paper for different kinds of paper production in the EU:

- printing writing: 5-50;
- paper board: 0-20;
- specialty paper: 10-300;
- and tissue: 10-50.

In Germany an average of 23.9 m³ per tonne of paper was found in a survey of 1997 (Böhm et al. 1997 in TGD (EC2003B)).

The amount of 15 m³/tonne, as used in the RIVM/FEI-scenario, is also used in the paper coating and finishing scenario (INERIS) that was drafted during EUBEES I and incorporated in the TGD (EC2003B).

4.2.3 Retention times

Different retention times in the mills and WWTPs are used in the different scenario-descriptions.

The **scenario of USES** does not use a retention time for the paper mill, because degradation of the slimicide in the paper mill itself is not considered in this scenario. In the **SNCI-scenarios** the values of the retention times are short (20 to 60 minutes) compared with the scenario of RIVM/FEI (4 hours). In view of the fact that a good part of the process water is recycled before discharge 20 to 60 minutes seems to be relatively short. It is not traceable on which basis the retention times of the SNCI-scenarios are determined.

The retention time of the **RIVM/FEI-scenario** is based on data in Sirkka, 2001 (in RIVM2002). The minimum retention time in Finnish paper mills, according to Sirkka, was 1-3 hours, median of the surveyed 69 machines was 8 hours and the average 15 hours. However it is not perfectly clear why the value of 4 hours was chosen, it was most probably to approach the realistic worst case situation. The retention time according to information in USES (although it isn't used in the scenario description) is 3-5 hours due to recycling. Therefore a retention time of 4 hours in the **RIVM/FEI-scenario** seems to represent a reasonable worst case scenario.

The retention times in the different stages of the WWTPs in the **SNCI-scenarios** are again not traceable. The retention times of the **RIVM/FEI-scenario** are based on the Finnish paper mill survey (Sirkka2001 in RIVM2002) and Braunschweiler, 1993 (in RIVM2002). Other information with respect to retention times of the water in papermills and their WWTPs in other EU countries are not available.

4.2.4 Wastewater treatment

In all scenarios only the emissions from the paper mill to different types of industrial WWTPs and from the WWTPs into fresh surface waters are described. Emissions directly to the sewer system, fresh surface water, estuaries or seawater are not considered.

It is difficult to say which kind of WWTP is most representative for situations in practice. The **USES scenario** considers a WWTP based on the standard STP-model of USES. The **SNCI-scenarios** consist of three completely separated scenarios with different WWTPs. According to the SNCI1995 the scenario for the fine paper mill with sedimentation and chemical treatment of the wastewater is most representative for the Swedish situation (data from 1995). The **RIVM/FEI-scenario** consists of a paper mill with three possible ways of wastewater treatment. Anaerobic treatment is not considered by any scenario description. This is, most probably, because this kind of wastewater treatment does not represent a worst case situation.

The TGD (EC2003B) assumes, that for a realistic worst case scenario it should be assumed that the waste water from the paper mill is treated only by mechanical and chemical means. This seems reasonable according to relatively recent data in the TGD (EC2003B). According to these data, the situation in the EU is, that the mill effluents in some Member States are usually (but not always) directed to on-site or municipal sewage treatment plants whereas in other member states the majority of paper mill effluents are not treated. In Finland, 8 of 24 paper and board mills have only minimal wastewater treatment (Sirkka 2001 in TGD (EC2003B)). This is also the case in the UK where only 1/3 of the paper mills treat their waste waters at all (OECD2002).

Van Dokkum et al. 1998 (in INFU2000) consider marine surface water as relevant. This has not been covered by an emission scenario. However, the TGD (EC2003) assumes that, in the case of discharges into seawater, chemical/mechanical treatment occurs.

4.2.5 Other emission routes

All scenarios assume that finally all added slimicides end up in the wastewater and that emissions to other compartments (such as adsorption to sludge, cellulose or particles and volatilisation to air) are negligible or only take place during waste water treatment (USES).

This implies the evaporation of water before discharging is not considered. The TGD (EC2003B) assumes an evaporation of 10 % of the water. This is due to processes at the "dry end" of the papermachine. It is not clear which amount of slimicide evaporates or adsorbs to the paper sheet.

It is also not clear if evaporation is relevant at the "wet-end" of the papermachine. When evaporation of the water in the "wet-end" is considered, the concentration of the slimicides in the effluent may be somewhat higher in case of non-volatile slimicides.

In chapter 3 is already mentioned that releases of slimicides to air are not considered relevant by the TGD (EC2003B). Emissions to air are also not considered relevant by Van Dokkum et. al. (in INFU2000) and OECD2002. In Braunschweiler, 1993a these emissions are considered insignificant, even during the drying process. This seems realistic, because most slimicides used in papermaking processes (table 2.1) are highly soluble in water.

On the other hand, according to measurements, monitoring studies and data based on practice in Sweden (SNCI1995), adsorption to cellulose fibres, particles and sludge in process and effluent waters may be important. But this is not certain. It depends on the properties of the slimicide. When using slimicides with high solubility in water it is unlikely that adsorption to sludge is important, but other compounds will sorb largely to particles (e.g. quaternary compounds).

Emissions from the wastewater treatment plants to the compartments air and sludge are only considered when Simple Treat is used (standard EU STP).

The scenario included in **USES** uses this standard STP-model with adapted values for the size of the STP and the dilution factors for discharge into surface water. In the **RIVM/FEI and SNCI scenarios**, with on-site company WWTPs, emissions to compartments other than surface water are not considered, although this may be relevant.

4.2.6 Degradation

In contrast to the other scenarios, the scenario described in **USES** does not consider elimination of the slimicide caused by hydrolysis in the paper mill. This is only taken into account during wastewater treatment, because of the use of the standard EU STP-model.

In the **SNCI-scenarios** biodegradation and hydrolysis are considered. The **RIVM/FEI-scenario** considers both biodegradation and hydrolysis in water and in WWTPs and photolysis in water. For more differences and similarities between the calculation methods for degradation see section 4.3: Overview of methods.

4.2.7 Discharge into receiving surface waters

As described earlier the discharges from the WWTPs in the described scenarios only take place in freshwaters. For the discharge to surface water default values for dilution factors are used in all scenarios:

- SNCI: 100
- RIVM/FEI: 10
- USES: - adapted values for stagnant waters: 3
 - semi-stagnant waters:10
 - large rivers: 100

In SNCI1995 it is indicated that, although a dilution factor of 100 is used in the **SNCI-scenarios**, dilution factors of 10 or even less exist (data from 1994), especially during low water levels in the summer time.

Due to the different seasonal, climatic and geographical conditions, dilution factors have been approximated to vary from 1 up to 100,000 (De Greef and De Nijs 1999 in ECO2000). In Finland in some situations the wastewater of some paper mills is not

diluted at all. It is very difficult to assess any concrete dilution factors even for a single paper mill (ECO2000).

The **RIVM/FEI -scenario** uses the default value of 10 for the dilution factor for discharge into surface water derived from the standard STP-model of USES, but the original Finnish scenario (Sirkka2001) uses a range of 1 to 1000. This range is used to estimate both the 'worst case' and 'best case' environmental concentrations in different use situations (according to Sirkka2001).

It is difficult to say which dilution factor is realistic to use for a realistic worst case scenario, because of the great differences per mill, per season and because more and more recycling of process water takes place with the result that a more concentrated wastewater flow is discharged.

The dilution factors used in the other scenarios (**SNCI and USES**) are determined on basis of relatively old data from 1992 and 1994.

Therefore the reasonable worst-case dilution factor may presently be higher than it used to be.

4.3 Overview of methods

In the original source documents, emission scenario calculations were provided. The original methods are presented in appendix 1 of this document. This section aims to present the calculation methods in a comparable way as far as possible, as to identify the main similarities and differences between them.

The calculation methods are given below. To facilitate comparison a standard notation and format is applied (Van der Poel 2000).

4.3.1 RIVM/FEI

Table 4.2 Common part of the models for the calculation of the theoretical average concentration (i.e. assuming no degradation) before wastewater treatment, depending on the way the dosage is expressed in the user's instructions. Concentration reduction due to degradation in process water is presented in table 3.7.

Variable/parameter	Unit	Symbol	Value	S/D/O/P
Input				
[A]				
Amount of biocide prescribed in user's instructions per tonne of dry paper	[g]	$Q_{\text{prod_uins}}$ or		S
Amount of wastewater for one tonne of dry paper	[ml] [m ³]	$V_{\text{prod_uins}}$ WW	15	D
[B]				
Amount of biocide prescribed in user's instructions per m ³ water	[g.m ⁻³] [ml.m ⁻³]	$Q_{\text{prod_uins}}$ or $V_{\text{prod_uins}}$		S
[A/B]				
Content of active ingredient in biocide preparation	[%] [g.l ⁻¹]	CONTENT		S
Specific density of biocidal	[kg.m ⁻³]	RHOprod	1000	D

Variable/parameter	Unit	Symbol	Value	S/D/O/P
product				
[B/C]				
Slimicide bearing fraction of the total wastewater flow coming from the short circulation of the wire part (%)	[-]	F _{ww1}	Treatment of both long and short circulation with slimicide: - yes: 100 - no: 60	P P
Fraction dilution of slimicide-free wastewater with wastewater from a pulp mill (%)	[-]	F _{ww2}	Connection to pulp mill: - yes: 50 - no: 0	P P
[C]	[mg.l ⁻¹]	C _{prescribed}		S
Concentration prescribed in the user's instructions				
Output:				
theoretical average concentration (i.e. assuming no degradation) before wastewater treatment	[mg.l ⁻¹]	C _{paper}		
Calculations:				
[A/B] Dose of a.i. (g.tonne ⁻¹ dry paper) ([A]) or dose of a.i. (g.m ⁻³ process water) ([B]), dependent on specifications for the amount of biocide preparation (Q _{prod_uins} / V _{prod_uins}) and content of a.i. in biocide preparation (CONTENT)				
		CONTENT	[A] Q _{prod_uins} /V _{prod_uins}	[B] Q _{prod_uins} /V _{prod_uins}
DOSE _{ai} = Q _{prod_uins} * CONTENT * 10 ⁻²		%	g	g.m ⁻³
DOSE _{ai} = Q _{prod_uins} * CONTENT / RHO _{prod}		g.l ⁻¹	g	g.m ⁻³
DOSE _{ai} = V _{prod_uins} * CONTENT * 10 ⁻⁵ * RHO _{prod}		%	ml	ml.m ⁻³
DOSE _{ai} = V _{prod_uins} * CONTENT * 10 ⁻³		g.l ⁻¹	ml	ml.m ⁻³
[A]	C _{paper} = DOSE _{ai} / WW			
[B]	C _{paper} = DOSE _{ai} * F _{ww1} * 0.01 * (1 - F _{ww2} / 100)			
[C]	C _{paper} = C _{prescribed} * F _{ww1} * 0.01 * (1 - F _{ww2} / 100)			

Table 4.3 Common part for the emission scenarios for calculating the release of slimicides in paper mills taking biodegradation and degradation due to hydrolysis and photolysis into account

Variable/parameter	Unit	Symbol	Value	S/D/O/P
Input				
Half-life for hydrolysis in acid circumstances	[d]	DT50hyd _{t_{acid}}		S
Half-life for hydrolysis in neutral circumstances	[d]	DT50hyd _{t_{water}} ¹⁾		S

Variable/parameter	Unit	Symbol	Value	S/D/O/P
Half-life for hydrolysis in alkaline circumstances	[d]	DT50hydr _{alkal}		S
Half-life for photolysis in water	[d]	DT50photo _{water}		S
Half-life for biodegradation for activated sludge	[d]	DT50bio _{stp} ²⁾	0.5	D
			DT50bio _{water}	
[I] Biodegradation test 12 hours light / 12 hours dark				
Half-life for biodegradation in water	[d]	DT50bioI _{water}		S
[II] Biodegradation test in the dark				
Half-life for biodegradation in water	[d]	DT50bioII _{water}		S

Output:

khydr _{acid}	=	rate constant for degradation due to hydrolysis at acid (pH5) conditions (d ⁻¹)
khydr _{water}	=	rate constant for degradation due to hydrolysis at neutral (pH7) conditions (d ⁻¹)
khydr _{alkal}	=	rate constant for degradation due to hydrolysis at alkaline (pH8) conditions (d ⁻¹)
kbiotot _{water}	=	rate constant for biodegradation in water including hydrolysis (d ⁻¹) and photolysis (d ⁻¹)
kbio _{water}	=	rate constant for biodegradation in water (d ⁻¹)
kbioh _{water}	=	rate constant for biodegradation in water including hydrolysis (d ⁻¹)
kbiotot _{stp}	=	rate constant for biodegradation in STPs including hydrolysis (d ⁻¹)
kphototot _{water}	=	rate constant for photolysis including hydrolysis (d ⁻¹)
kphoto _{water}	=	rate constant for photolysis (d ⁻¹)

Calculations:

khydr _{acid}	=	$\ln 2 / DT50hydr_{acid}$
khydr _{water}	=	$\ln 2 / DT50hydr_{water}$
khydr _{alkal}	=	$\ln 2 / DT50hydr_{alkal}$
kphototot _{water}	=	$\ln 2 / DT50photo_{water}$
kphoto _{water}	=	$kphototot_{water} - khydr_{water}$
kbiotot _{stp}	=	$\ln 2 / DT50bio_{stp}$
[I]		
kbiotot _{water}	=	$\ln 2 / DT50bioI_{water}$
kbioh _{water}	=	$kbiotot_{water} - kphoto_{water}$
kbio _{water}	=	$kbiotot_{water} - khydr_{water}$
[II]		
kbioh _{water}	=	$\ln 2 / DT50bioII_{water}$
kbio _{water}	=	$kbioh_{water} - khydr_{water}$
kbiotot _{water}	=	$kbioh_{water} + kphoto_{water}$

¹⁾ This symbol is already used in EUSES.

²⁾ Depending on the availability of DT50bioI_{water} or DT50bioII_{water} (This is a conservative estimate according to the RIVM/FEI -scenario. The basis for this assumed relation is not presented in the RIVM/FEI description. From a theoretical point of view it can not be justified)

Table 4.4 Model for the calculation of the relevant PECs depending on the user's instructions: [A] amount of biocide per tonne of product and [B/C] amount of biocide per m³ of water at the wire part of the paper machine.

Variable/parameter	Unit	Symbol	Value	S/D/O/P
Input:				
Theoretical concentration of a.i.	[kg.m ⁻³]	C _{paper}		
Retention time for paper making process	[h]	T _{ph}	4	D
Retention time for primary settling	[h]	T _{ps_h}	4	D
Retention time for the short term activated sludge unit	[h]	T _{as_h}	4	D
Retention time for secondary settling	[h]	T _{ss_h}	4	D
Retention time for chemical/mechanical treatment	[h]	T _{cm_h}	4	D
Retention time for the long-term activated sludge unit	[h]	T _{bt_h}	40	D
Dilution factor at discharge surface water	[-]	DILUTION _{paper}	10 ¹⁾	D
Output:				
PEC _{ASstp_acid}	=	Predicted environmental concentration for assessment of micro-organisms in STP with short term activated sludge for acid conditions during the paper making process (mg.l ⁻¹)		
PEC _{ASstp_neutr}	=	Predicted environmental concentration for assessment of micro-organisms in STP with short term activated sludge for neutral conditions during the paper making process (mg.l ⁻¹)		
PEC _{ASstp_alkal}	=	Predicted environmental concentration for assessment of micro-organisms in STP with short term activated sludge for alkaline conditions during the paper making process (mg.l ⁻¹)		
PEC _{BTstp_acid}	=	Predicted environmental concentration for assessment of micro-organisms in STP with a long-term biological treatment for acid conditions during the paper making process (mg.l ⁻¹)		
PEC _{BTstp_neutr}	=	Predicted environmental concentration for assessment of micro-organisms in STP with a long-term biological treatment for neutral conditions during the paper making process (mg.l ⁻¹)		
PEC _{BTstp_alkal}	=	Predicted environmental concentration for assessment of micro-organisms in STP with a long-term biological treatment for alkaline conditions during the paper making process (mg.l ⁻¹)		
PEC _{ASstp_acid}	=	Predicted environmental concentration for assessment of micro-organisms in STP with short term activated sludge for acid conditions during the paper making process (mg.l ⁻¹)		
PEC _{ASstp_neutr}	=	Predicted environmental concentration for assessment of micro-organisms in STP with short term activated sludge for neutral conditions during the paper making process (mg.l ⁻¹)		
PEC _{ASstp_alkal}	=	Predicted environmental concentration for assessment of micro-organisms in STP with short term activated sludge for alkaline conditions during the paper making process (mg.l ⁻¹)		
PEC _{BTstp_acid}	=	Predicted environmental concentration for assessment of micro-organisms in STP with a long-term biological treatment for acid conditions during the paper making process (mg.l ⁻¹)		

Variable/parameter	Unit	Symbol	Value	S/D/O/P
PEC _{BTstp_neutr}	=		Predicted environmental concentration for assessment of micro-organisms in STP with a long-term biological treatment for neutral conditions during the paper making process (mg.l ⁻¹)	
PEC _{BTstp_alkal}	=		Predicted environmental concentration for assessment of micro-organisms in STP with a long-term biological treatment for alkaline conditions during the paper making process (mg.l ⁻¹)	
PEClocal _{AS_water_acid}	=		Predicted Environmental Concentration in receiving surface water after short term activated sludge treatment for acid process conditions in the paper making process (mg.l ⁻¹)	
PEClocal _{AS_water_neutr}	=		Predicted Environmental Concentration in receiving surface water after short term activated sludge treatment for neutral process conditions at paper making (mg.l ⁻¹)	
PEClocal _{AS_water_alkal}	=		Predicted Environmental Concentration in receiving surface water after short term activated sludge treatment for alkaline process conditions in the paper making process (mg.l ⁻¹)	
PEClocal _{CM_water_acid}	=		Predicted Environmental Concentration in receiving surface water after chemical/mechanical treatment for acid process conditions in the paper making process (mg.l ⁻¹)	
PEClocal _{CM_water_neutr}	=		Predicted Environmental Concentration in receiving surface water after chemical/mechanical treatment for neutral process conditions at paper making (mg.l ⁻¹)	
PEClocal _{CM_water_alkal}	=		Predicted Environmental Concentration in receiving surface water after chemical/mechanical treatment for alkaline process conditions in the paper making process (mg.l ⁻¹)	
PEClocal _{BT_water_acid}	=		Predicted Environmental Concentration in receiving surface water after long-term biological treatment for acid process in the paper making process (mg.l ⁻¹)	
PEClocal _{BT_water_neutr}	=		Predicted Environmental Concentration in receiving surface water after long-term biological treatment for neutral process conditions in the paper making process (mg.l ⁻¹)	
PEClocal _{BT_water_alkal}	=		Predicted Environmental Concentration in receiving surface water after long-term biological treatment for alkaline process conditions in the paper making process (mg.l ⁻¹)	

Intermediate calculations:

Variable/parameter	Unit	Symbol	Value	S/D/O/P
Retention times (d) for paper making process, primary settling, short term activated sludge treatment, secondary settling, chemical/mechanical treatment and long-term biological treatment respectively:				

$$T_{pr} = T_{prh} / 24$$

$$T_{ps} = T_{ps_h} / 24$$

$$T_{as} = T_{as_h} / 24$$

$$T_{ss} = T_{ss_h} / 24$$

$$T_{cm} = T_{cm_h} / 24$$

$$T_{bt} = T_{bt_h} / 24$$

Concentrations after primary settling for acid, neutral and alkaline process conditions respectively (mg.l^{-1}):

$$C_{acid} = C_{paper} * e^{-((k_{bio_{water}} + k_{hyd_{acid}}) * T_{pr} + k_{biot_{water}} * T_{ps})}$$

$$C_{neutr} = C_{paper} * e^{-k_{biot_{water}} * (T_{pr} + T_{ps})}$$

$$C_{alkal} = C_{paper} * e^{-((k_{bio_{water}} + k_{hyd_{alkal}}) * T_{pr} + k_{biot_{water}} * T_{ps})}$$

Concentrations after secondary settling in the case of short term activated sludge treatment (mg.l^{-1})

$$C_{acid_{AS}} = C_{acid} * e^{-(k_{biot_{stp}} * T_{as} + k_{biot_{water}} * T_{ss})}$$

$$C_{neutr_{AS}} = C_{neutr} * e^{-(k_{biot_{stp}} * T_{as} + k_{biot_{water}} * T_{ss})}$$

$$C_{alkal_{AS}} = C_{alkal} * e^{-(k_{biot_{stp}} * T_{as} + k_{biot_{water}} * T_{ss})}$$

Concentrations after chemical/mechanical treatment (mg.l^{-1}):

$$C_{acid_{CM}} = C_{acid} * e^{-k_{biot_{water}} * T_{cm}}$$

$$C_{neutr_{CM}} = C_{neutr} * e^{-k_{biot_{water}} * T_{cm}}$$

$$C_{alkal_{CM}} = C_{alkal} * e^{-k_{biot_{water}} * T_{cm}}$$

Concentrations after long-term biological treatment (mg.l^{-1}):

$$C_{acid_{BT}} = C_{acid} * e^{-T_{bt} * (k_{biot_{water}} + 0.5k_{photo_{water}})}$$

$$C_{neutr_{BT}} = C_{neutr} * e^{-T_{bt} * (k_{biot_{water}} + 0.5k_{photo_{water}})}$$

$$C_{alkal_{BT}} = C_{alkal} * e^{-T_{bt} * (k_{biot_{water}} + 0.5k_{photo_{water}})}$$

End calculations:

Variable/parameter	Unit	Symbol	Value	S/D/O/P
PEC in aeration tank for short term activated sludge treatment for acid, neutral and alkaline process conditions respectively (mg/l):				

$$PEC_{ASstp_acid} = C_{acid} * e^{-0.5 * k_{biot} t_{stp} * T_{as}}$$

$$PEC_{ASstp_neutr} = C_{neutr} * e^{-0.5 * k_{biot} t_{stp} * T_{as}}$$

$$PEC_{ASstp_alkal} = C_{alkal} * e^{-0.5 * k_{biot} t_{stp} * T_{as}}$$

PEC in aeration basin for long-term biological treatment for acid, neutral and alkaline process conditions respectively (mg/l):

$$PEC_{BTstp_acid} = C_{acid} * e^{-0.5 * T_{bt} * (k_{biot} t_{water} + 0.5 k_{phot} t_{water})}$$

$$PEC_{BTstp_neutr} = C_{neutr} * e^{-0.5 * T_{bt} * (k_{biot} t_{water} + 0.5 k_{phot} t_{water})}$$

$$PEC_{BTstp_alkal} = C_{alkal} * e^{-0.5 * T_{bt} * (k_{biot} t_{water} + 0.5 k_{phot} t_{water})}$$

PEC in receiving surface water after short term activated sludge treatment for acid, neutral and alkaline process conditions respectively (mg/l):

$$PEC_{local\ AS_water_acid} = C_{acid\ AS} / DILUTION_{paper}$$

$$PEC_{local\ AS_water_neutr} = C_{neutr\ AS} / DILUTION_{paper}$$

$$PEC_{local\ AS_water_alkal} = C_{alkal\ AS} / DILUTION_{paper}$$

PEC in receiving surface water after chemical/mechanical treatment for acid, neutral and alkaline process conditions respectively (mg/l):

$$PEC_{local\ CM_water_acid} = C_{acid\ CM} / DILUTION_{paper}$$

$$PEC_{local\ CM_water_neutr} = C_{neutr\ CM} / DILUTION_{paper}$$

$$PEC_{local\ CM_water_basic} = C_{alkal\ CM} / DILUTION_{paper}$$

PEC in receiving surface water after long-term biological treatment for acid, neutral and alkaline process conditions respectively (mg/l):

$$PEC_{local\ BT_water_acid} = C_{acid\ BT} / DILUTION_{paper}$$

$$PEC_{local\ BT_water_neutr} = C_{neutr\ BT} / DILUTION_{paper}$$

$$PEC_{local\ BT_water_alkal} = C_{alkal\ BT} / DILUTION_{paper}$$

¹⁾ Default value of USES

4.3.2 SNCI

Fine paper mill

Table 4.5 Emission scenario for calculating the releases from slimicides used in a fine paper mill (SNCI1995).

Variable/parameter	Unit	Symbol	Value	S/D/O/P
Input				
Concentration of the active ingredient in the white water during dosing periods	[kg.m ⁻³]	C _{whitewater,prescribed}		S
Volume of the white water circuit	[m ³]	V _{proces}	300	D
Number of dosing periods	[-]	N _{dose}	2	D
Amount of waste water per day	[m ³]	V _{wastewater}	5,000	D
Degradation rate due to hydrolysis of specific slimicide in phases of dissipation x	[d ⁻¹]	k _{hydr,x}		S
Duration of the phases of dissipation	[d]	tk,x		S
Retention time for paper making process	[d]	T _{ph}	1/36 at 50°C and pH 4.5	D
Retention time for primary settling (sedimentation and chemical treatment)	[d]	T _{ps,c}	10/12 at 35°C and pH 7	D
Total retention time	[d]	T _{tot}	31/36	D
Dilution factor at discharge surface water	[-]	DILUTION _{paper}	100	D
Output:				
Predicted Environmental Concentration in receiving surface water after primary settling (sedimentation and chemical treatment)	[kg.m ³]	PEC _{local,ps,c}		
Intermediate calculations:				
Dose of active ingredient (kg) (calculation as described in SNCI1995)				
$DOSE_{ai} = C_{white\ water,prescribed} * V_{proces}$				
Theoretical average concentration before waste water treatment (assuming that no degradation has occurred yet) (kg.m ⁻³)				
$C_{paper} = DOSE_{ai} * N_{dose} / V_{wastewater}$				
End calculation:				
$PEC_{local,ps,c} = C_{paper} * e^{S(-k_{hydr,x}*tk,x)} / DILUTION_{paper}$				

Newspaper mill (about 2 days retention time)

Table 4.6 Emission scenario for calculating the releases from slimicides used in a newspaper mill with about 2 days retention time (SNCI1995).

Variable/parameter	Unit	Symbol	Value	S/D/O/P
Input				
Concentration of the active ingredient in the white water during dosing periods	[kg.m ⁻³]	C _{whitewater,prescribed}		S
Volume of the white water circuit	[m ³]	V _{proces}	1000	D
Number of dosing periods	[-]	N _{dose}	2	D
Amount of waste water per day	[m ³]	V _{wastewater}	25,000	D
Dissipation rate due to hydrolysis of specific slimicide in phases of dissipation x	[d ⁻¹]	k _{hydr,x}		S
Dissipation rate due to biodegradation of specific slimicide in phases of dissipation x	[d ⁻¹]	k _{bio,x}		S
Duration of the phases of dissipation	[d]	tk,x		S
Retention time for paper making proces	[d]	T _{pr}	1/24 at 50°C and pH 4.5	D
Retention time for primary settling (only sedimentation)	[d]	T _{ps}	1/2 at 35°C and pH 7	D
Retention time for the activated sludge unit	[d]	T _{as}	10/12 at 30°C and pH 7	D
Retention time for secondary settling	[d]	T _{ss}	5/8 at 25°C and pH 7	D
Total retention time	[d]	T _{tot}	2	
Dilution factor at discharge surface water	[-]	DILUTION _{paper}	100	D
Output:				
Predicted Environmental Concentration in receiving surface water after primary settling (sedimentation and chemical treatment)	[kg.m ⁻³]	PEC _{local,ps,c}		
Intermediate calculations:				
$DOSE_{ai} = C_{whitewater,prescribed} * V_{proces}$				
Theoretical average concentration before waste water treatment (assuming that no degradation has occurred yet) (kg.m ⁻³)				
$C_{paper} = DOSE_{ai} * N_{dose} / V_{wastewater}$				
End calculation:				
The notation of the calculation of PEC _{local,ps,c} in a standard formula is not possible with help of the data in SNCI1995.				

Newspaper mill (about 1 day retention time)

Table 4.7 Emission scenario for calculating the releases from slimicides used in a newspaper mill with about 1 day retention time (SNCI1995).

Variable/parameter	Unit	Symbol	Value	S/D/O/P
Input				
Concentration of the active ingredient in the white water during dosing periods	[kg.m ⁻³]	C _{whitewater,prescribed}		S
Volume of the white water circuit	[m ³]	V _{proces}	300	D
Number of dosing periods	[-]	N _{dose}	2	D
Amount of waste water per day	[m ³]	V _{wastewater}	28,000	D
Dissipation rate due to hydrolysis of specific slimicide in phases of dissipation x	[d ⁻¹]	k _{hydr,x}		S
Dissipation rate due to biodegradation of specific slimicide in phases of dissipation x	[d ⁻¹]	k _{bio,x}		S
Duration of the phases of dissipation	[d]	tk,x		S
Retention time for paper making proces	[d]	T _{pr}	1/72 at 50°C and pH 4.5	D
Retention time for primary settling (only sedimentation)	[d]	T _{ps}	5/24 at 35°C and pH 7	D
Retention time for the activated sludge unit	[d]	T _{as}	1/2 at 30°C and pH 7	D
Retention time for secondary settling	[d]	T _{ss}	5/24 at 25°C and pH 7	D
Total retention time	[d]	T _{tot}	67/72	
Dilution factor at discharge surface water	[-]	DILUTION _{paper}	100	D
Output:				
Predicted Environmental Concentration in receiving surface water after primary settling (sedimentation and chemical treatment)	[kg.m ⁻³]	PEC _{local,ps,c}		
Intermediate calculations:				
$DOSE_{ai} = C_{whitewater,prescribed} * V_{proces}$				
Theoretical average concentration before waste water treatment (assuming that no degradation has occurred yet) (kg.m ⁻³)				
$C_{paper} = DOSE_{ai} * N_{dose} / V_{wastewater}$				
End calculation:				
The notation of the calculation of PEC _{local,ps,c} in a standard formula is not possible with help of the data in SNCI1995.				

4.3.3 USES 3.0

Table 4.8 Emission scenario for calculating the releases from slimicides used in a paper mill (INFU2000).

Variable/parameter	Unit	Symbol	Value	S/D/O/P
Input:				
Amount of waste water per day	[m ³ .d ⁻¹]	Q _{wastewater}	3,000	D
Theoretical average concentration before waste water treatment (assuming no degradation)	[kg.m ⁻³]	C _{paper}		S
Capacity of STP	[m ³ .d ⁻¹]	Q _{STP}	3,000 ¹⁾	D
Fraction directed to surface water in STP (calculation by standard module of USES)	[-]	F _{STP}		O
Dilution factor at discharge surface water (stagnant)	[-]	DILUTION _{paper, stagnant}	3 ¹⁾	D
Dilution factor at discharge surface water (semi-stagnant)	[-]	DILUTION _{paper, semistagnant}	10 ¹⁾	D
Dilution factor at discharge surface water (large rivers)	[-]	DILUTION _{paper, large rivers}	100 ¹⁾	D
Output:				
Predicted Environmental Concentration in receiving surface water	[kg.m ⁻³]	PEC _{local}		
Model calculations:				
PEC _{local} = C _{paper} * F _{STP} / DILUTION _{paper}				

1) Adapted values for standard STP-model of USES

4.4 Qualitative comparison of the methods

In this section the methods for the calculation of the concentration in the receiving compartments surface water, sludge and air are discussed.

The first step in the calculation of environmental concentrations is to calculate the emission, in a second step this quantity or concentration is divided by the dilution factor. The main similarities and differences between the methods are indicated below for both steps.

4.4.1 Calculation of emissions

Quantity emitted

None of the scenarios calculate a quantity emitted. Every scenario uses average slimicide concentrations in the paper mill to calculate concentrations in eventual water treatment steps and eventually in the receiving surface water.

As already mentioned the **RIVM/FEI approach** does not calculate the quantity emitted, but calculates the concentration of slimicides in the effluent of several industrial WWTPs. This is calculated either by:

- dividing the dose of the active ingredient per tonne of paper by the amount of wastewater per tonne of paper (A);
- or by using the prescribed dose to the process water or the prescribed concentration in the process water. In this case the influence of dilution of this concentration by slimicide-free water from a pulp mill or from the long circulation of the paper mill can be calculated (B/C).

After this, the amount of slimicide that is removed due to biodegradation, hydrolysis and photolysis is calculated.

The **SNCI-scenario** uses the concentration to be established in the white water during dosing periods to calculate the concentration in the total wastewater stream. The eventual emission to the receiving environmental compartment surface water is calculated from the fraction of slimicide that is removed due to biodegradation and hydrolysis.

The **USES-scenario** calculates the concentration in the effluent of the WWTP by multiplying the prescribed concentration in the white water (assumed to be discharged with the same concentration) with the fraction removed by the WWTP (calculation by standard module of USES). In contrast with the other two scenarios degradation and hydrolysis is only taken into account in the WWTP. Another difference with the other two scenarios is that the emissions to the compartments air and sludge in the WWTP are calculated because of the use of the standard STP-model.

Degradation

In the **RIVM/FEI-scenario** degradation of the active ingredient in the paper mill and the WWTPs is considered. In contrast with the other scenarios, this scenario assumes biodegradation in the paper mill and primary and secondary treatment steps. The other two scenarios assume biodegradation only in biological wastewater treatment steps. This seems logical, because slimicides are used to prevent the growth of microorganisms. However, biodegradation may take place, depending on the water characteristics, but it is not possible to determine the rate.

To calculate the degradation of the chemical, the degradation rates for biodegradation, hydrolysis and photolysis are taken into account. Degradation rates for different circumstances are used, e.g. for different pH in the paper machine or WWTP environment. Using degradation rates for different pH may only have a significant effect for easily degradable substances (according to Sirkka2001 in RIVM2002). To calculate the fraction of the chemical that is degraded, the retention times of the paper mill and the various compartments of the WWTPs are multiplied with the dissipation rates for the specific compartments. Corrections for temperature are not considered in the scenario calculations. When comparing several slimicides

the worst case would normally be sufficient. In the scenario description however the possibility for correction by the Arrhenius and van 't Hoff equations is 'described'. In the original FEI-scenario it is assumed by default that the degradation rate is 2 times faster with every 10 degrees temperature rise within the relevant temperature range.

In the **SNCI-scenario** biodegradation and hydrolysis are taken into account. However, it is not clear how the fraction of the active ingredient removed due to biodegradation and hydrolysis is calculated in this scenario.

In an example calculation, elaborated in the scenario description, dissipation rates for hydrolysis in different dissipation phases are used. To calculate the fraction of the chemical that is degraded, the time length of the different dissipation phases is multiplied with the specific dissipation rate. It is to be expected that the different retention times of the paper mill and the various compartments of the WWTPs correspond with the so called time length of the different dissipation phases. But according to the scenario description of the SNCI-scenario this is not the case. This is rather strange because the circumstances for hydrolysis and biodegradation are different for each process step. In contrast with the RIVM/FEI-scenario only the total retention time of the entire process, before discharging into the receiving surface water, is used in the calculation. Corrections for pH and temperature are not considered.

The **USES-scenario** does not calculate the fraction degraded in the paper mill. The degradation of the chemical in the WWTP is calculated with the standard STP-model.

- 4.4.2 Calculation of the environmental concentration in the compartments surface water, sludge and air

Surface water

All methods calculate the emission to the surface water by dividing the concentration of the active ingredient in the discharged effluent of the WWTPs by a dilution factor for discharge into surface water.

Air and sludge

Emissions from the paper mill to air and sludge are not considered in the scenarios. The USES-scenario is the only one that calculates these emissions from the WWTP (by using the standard STP-model).

4.5 **Detection of similarities and differences, comparison and examples**

To show how the differences between the calculation methods work out for different scenarios, an example is elaborated in detail. Only the scenarios of USES and RIVM/FEI are chosen for this example, because it is not clear how the calculations of the Swedish scenarios are performed.

An example is taken for three "dummy" substances. The example substances are:
Dummy 1: Poorly biodegradable, no hydrolysis and high log Kow.
Dummy 2: Inherently biodegradable, no hydrolysis and low log Kow.
Dummy 3: Inherently biodegradable, low log Kow and hydrolysis is an important mechanism.

It is difficult to compare the two scenarios, because the scenarios of USES and RIVM/FEI use different ways to calculate the concentration in the wastewater before discharge (assuming no degradation). This concentration depends on the user's instructions of the substance. Therefore the choice was made to use C_{paper} as the primary input value for the example calculations.

The input values are listed in table 4.9 below, where the parameters are indicated as "dummy" (S), "default" (D) or "result" (O). Dummy means that this is a chosen value and default is a value that is given in the original scenarios or methods. Results are calculated from dummies and defaults.

The fractions of the active ingredient directed to the compartments surface water, air and sludge for the USES -scenario are obtained from a calculation with the standard STP model of USES. The calculated fractions (results) are given in table 4.9.

It is assumed that biodegradation only occurs in biological water treatment systems and not in the paper mill and primary and secondary treatment steps, as suggested in the RIVM/FEI-scenario. Furthermore, a dilution factor of 10 was chosen for both scenarios, so $C_{\text{local water}}$ is calculated for the same discharge situation.

Table 4.9 Input values for the calculation of $C_{\text{local water}}$.

Parameter	Symbol	Unit	Value	S/D/O
Input				
Theoretical average concentration (assuming no degradation) before wastewater treatment	C_{paper}	[mg.l ⁻¹]	10 (OECD)	S
Fractions of the a.i. directed to the compartments surface water, air and sludge (standard STP)	$F_{\text{STP,water}}$ $F_{\text{STP,air}}$ $F_{\text{STP,sludge}}$	[-]	Substance 1: $F_{\text{STP,water}} = 0.846$ $F_{\text{STP,air}} = 0.025$ $F_{\text{STP,sludge}} = 0.129$ Substance 2: $F_{\text{STP,water}} = 0.592$ (40.8% of the substance is degraded) Substance 3: $F_{\text{STP,water}} = 0.509$ (34.5% of the substance is degraded) $F_{\text{STP,air}} = 0$ $F_{\text{STP,sludge}} = 0.146$	O
Rate constant for biodegradation in STP	$K_{\text{biO}_{\text{STP}}}$	[d ⁻¹]	Substance 1: 0 Substance 2: 2.4 Substance 3: 2.4	S
Rate constant for degradation due to hydrolysis in water	$K_{\text{hydr}_{\text{water}}}$	[d ⁻¹]	Substance 1: 0 Substance 2: 0 Subst. 3: pH5: 1.93 pH7: 6.40 pH9: 11.39	S
Rate constant for photolysis in water	$K_{\text{photo}_{\text{water}}}$	[d ⁻¹]	0	S
Octanol/water partition coefficient	Log Kow	[-]	Substance 1: 3.1 Substance 2: -0.64 Substance 3: 0.163	S
Solubility in water	$S_{\text{ol}_{\text{water}}}$	[mg.l ⁻¹]	Substance 1: 28.2	S

Parameter	Symbol	Unit	Value	S/D/O
			Substance 2: 62800 Substance 3: 3600	
Dilution factor at discharge surface water	DILUTION _{paper}	[-]	10	D
Retention time for paper making process	T _{pr}	[d]	0.167	D
Retention time for primary settling	T _{ps}	[d]	0.167	D
Retention time for the activated sludge unit	T _{as}	[d]	0.167	D
Retention time for secondary settling	T _{ss}	[d]	0.167	D
Retention time for chemical/mechanical treatment	T _{cm}	[d]	0.167	D
Retention time for long-term biological treatment	T _{bt}	[d]	1.67	D

A summary of calculated $C_{\text{local water}}$ is given in table 4.10. In these tables, the $C_{\text{local water}}$ in $[\text{mg}\cdot\text{m}^{-3}]$ for the RIVM/FEI- and USES-scenarios for slimicides are given. The full calculations are given in appendix 2.

Table 4.10 $C_{\text{local water}}$ in $[\text{mg}\cdot\text{l}^{-1}]$ for the three substances

Scenario	Substance 1	Substance 2	Substance 3 ¹⁾
RIVM/FEI			
Paper mill with treatment in an short term activated sludge unit (16 hours total retention time)	1	0.67	pH5: 0.185 pH7: 0.00937 pH9: 0.000337
Paper mill with chemical/mechanical wastewater treatment (12 hours total retention time)	1	1	pH5: 0.381 pH7: 0.0406 pH9: 0.00336
Paper mill with long term biological treatment (2 days total retention time)	1	0.14	pH5: 0.00285 pH7: $3.72\cdot 10^{-7}$ pH9: $1.73\cdot 10^{-11}$
USES			
Paper mill with WWTP (standard STP with adapted values)	0.85 (2.5% to air and 12.9% to sludge, no degradation)	0.59 (40.8% degraded, 0% to sludge and air)	0.51 (34.5% degraded, 14.6% to sludge, 0% to air)

1) Because the hydrolysis rate of dummy 3 is known for acid, neutral and alkaline conditions, the PE_{effluent} is given for pH5, pH7 and pH9. However, in this calculations the rate for biodegradation is equal for every pH.

Conclusions

The following conclusions can be derived from these exercises:

- Consideration of degradation due to hydrolysis is important. The differences between substance 1 and 2 (where hydrolysis is not considered) and substance 3 (where hydrolysis is considered) are significant.
- Significant differences are also found between PECs_{local water} due to hydrolysis rates for different pHs. It is important to be able to make a difference between several pHs in the case a certain slimicide has to be used at a certain pH range (information supplier).
- For more lipophilic substances like substance 1, adsorption to sludge during wastewater treatment is relatively important (12.9%) according to calculations with the standard STP-model of USES. Emissions to air can be considered negligible. Even for substance 1 with a lower solubility in water as compared to most substances used in papermaking processes, the emission to air is only 2.5%.
- When biodegradation during biological water treatment occurs, as with substance 2, the retention time of the biological treatment step is important. The emission, calculated with the RIVM/FEI-scenario for a paper mill with long term biological treatment, is very small. The fraction removed due to biodegradation calculated for substance 2 within the USES-scenario is of the same order of magnitude compared with the calculation of the RIVM/FEI-scenario for a paper mill with treatment in a short term activated sludge unit.
- The worst case scenario according to these calculations would be the RIVM/FEI-scenario for a paper mill with chemical and mechanical treatment. Even when hydrolysis is important for a certain slimicide, the predicted concentration in the receiving surface water for this scenario is the highest value compared with the other scenarios of RIVM/FEI and USES, because this scenario has the shortest retention time in the entire process.
- The predicted concentration in the effluent for the RIVM/FEI-scenario for a paper mill with chemical and mechanical treatment may be somewhat lower if adsorption to paper sludge is taken into account.

5 DISCUSSION ON SLIMICIDES IN PAPER PRODUCTION PROCESSES

5.1 Dimensions and characteristics of the point sources (including on site waste water treatment plants) and receiving environmental compartments

The basis for the dimensions and parameters of the **SNCI-scenario** is not clear, neither is it clear how the calculations for this scenario are performed. Dilution factors for discharge into surface water used in the scenarios are based on historic data (1992-1994). The dilution factor 10, for discharge on surface water, referred in the **RIVM/FEI-scenario** is a joint Dutch/FIN estimate (the original FEI-scenario, based on more recent data from Sirkka2001, uses a range of 1 to 1000 for the dilution factor. This range is used to calculate concentrations from 'worst case' to 'best case' situations).

It is not clear whether the used factors are still correct for the present situation in the paper industry. The water use is continuously being reduced due to recycling. Next to this there is a great variety in dilution factors per mill and even per season, so that it is very difficult to assess one average value for a reasonable worst case situation.

The original RIVM/FEI scenario assumes that the waste water is not diluted before discharge into the WWTP, but uses only retention times. The RIVM/FEI-scenario assumes an average paper production of 200 tonnes of paper per day and 15 m³ of waste water per tonne paper. When multiplying 15 with 200 the waste water flow is 3000 m³/day. This equals the amount of waste water treated in a standard STP in the USES-scenario. DILUTION_{STP} would be 1. It would be strange that the wastewater from a paper mill forms the total amount of wastewater in the STP. Taken this problem into consideration it is proposed to use the Simple Treat method to calculate the degradation in the wastewater treatment step, but to follow the assumption of the RIVM/FEI-scenario that the waste water is treated in a WWTP (DILUTION_{WWTP} = 1).

[REMARK: The TGD (EC2003B) proposes an STP with a capacity of 5000 m³/day to solve this problem. However, the system volume of STPs (or WWTPs) does not influence the outcome of the calculation of the resulting emissions. If just the system volume is changed, using a constant influent concentration, the effluent concentration remains the same. However, when an influent load is used the system capacity of a WWTP is important. In this case the system capacity has to be determined on a case by case basis.]

None of the scenarios consider evaporation of the water before discharging. According to the TGD (EC2003B) an evaporation of 10 % of the water in the dryer section of the papermachine occurs. When evaporation in the wet-end is considered, the concentration of the slimicides in the effluent may be somewhat higher (in case of non-volatile slimicides).

It's not certain whether a significant amount of slimicides adsorbs to paper particles in the paper mill.

The retention times in the different stages of the WWTPs used in the **SNCI-scenarios** are not traceable. The retention times of the **RIVM/FEI-scenario** are based on the Finnish paper mill survey (Sirkka2001 in RIVM2002) and Braunschweiler, 1993 (in RIVM2002). Other information with respect to retention

times of the water in papermills and their WWTPs in other EU countries is not available.

5.2 Degradation

In the **SNCI-scenario** biodegradation and hydrolysis are taken into account.

However, it is not clear how the fractions of the active ingredient removed due to biodegradation and hydrolysis are calculated in this scenario.

To calculate the fraction of the chemical that is degraded, the length of time of the different degradation phases is multiplied with the specific degradation rate. It is to be expected that the different retention times of the paper mill and the various compartments of the WWTPs correspond with the so-called time length of the different dissipation phases. But according to the scenario description of the **SNCI-scenario** this is not the case. This is rather strange because the circumstances for hydrolysis and biodegradation are different for every process step. Only the total retention time of the entire process, before discharging on the receiving surface water, is used in the calculation.

In contrast with the other scenarios of **USES** and **SNCI**, the **RIVM/FEI-scenario** assumes biodegradation in the paper mill and wastewater treatment steps without active sludge. Biodegradation may take place to some extent, but the basis for the assumption that the DT50 in water is twice the DT50 for biodegradation in an STP is not clear. This assumption should not be made.

Corrections for pH and temperature are only considered in the **RIVM/FEI-scenario**. The question is if this is not too detailed for a calculation model. This seems more useful when performing calculations at an actual paper mill when the exact process conditions are known. However, when a certain slimicide is meant to be used at a certain pH range (information supplier), it may be useful to be able to perform calculations with degradation rates for different pHs.

5.3 Formulation of the elimination processes

In the scenarios presented in the previous sections the addition of the biocides was always assumed to be intermittent, as a dose given during short intervals (30 to 60 minutes) for 2 to 3 times per day. The elimination processes can be described by a first order reaction related to the concentration of the biocide in the process water. This implies that the fraction degraded by hydrolysis and/or photolysis can be calculated based on a first-order reaction rate constant $k_{hydrolysis}$ and/or $k_{photodeg}$ (' K_{elim} ') and time or the Hydraulic Residence Time (HRT). A distinction is to be made between systems treated with a shock dose and systems that are dosed continuously.

A dosage pattern with a shock dose or short intervals (30 to 60 minutes for about 2 or 3 times per day) leads to a fluctuation of the concentration in the process water in time:

$$C_{out} = C_{paper} * e^{-K_{elim} * HRT}$$

In this case it can be interesting to know the maximum as well as the average concentration in the outlet.

When slimicides are recommended in schemes with longer intervals (semicontinuous, e.g. 1 to 2 hours for 4 to 6 times per day) or continuous dosages,

the concentration in the system does not fluctuate but remains constant at the level (Weber 1972):

$$C_{out} = C_{paper} / (1 + Kelim * HRT)$$

5.4 Conclusions

Biodegradation during the process is not considered relevant.

The SNCI-scenario is not suitable to use as a method to predict emissions of slimicides from paper mills.

After considering the analyses carried out in this report, the RIVM/FEI-scenario for a paper mill with chemical mechanical treatment of the waste water is considered to be a realistic worst case scenario. In contrast with the USES-scenario this scenario considers hydrolysis in the paper mill. According to the calculations in section 4.5 hydrolysis may be important for certain slimicides. Furthermore, the RIVM/FEI-scenario assumes by default (and a realistic worst case situation) that:

- both the short and long circulation water are treated with slimicide,
- and there is no connection to a pulp mill.

However the possibility exists to change these default parameters.

The predicted concentration in the receiving surface water for the RIVM/FEI-scenario with mechanical/chemical treatment gives the highest concentrations compared to the other scenarios of RIVM/FEI and USES, because this scenario has the shortest retention time in the entire process.

The predicted concentration in the effluent for the RIVM/FEI-scenario for a paper mill with chemical and mechanical treatment may be somewhat lower when adsorption to paper particles and sheets in the paper mill is taken into account. According to calculations with USES emissions to sludge (in an STP) are important in case of more lipophilic chemicals. Emissions to air can be considered negligible.

Biodegradation in paper mill processes as described in the RIVM/FEI-scenario is questionable. No appropriate data are available to calculate it. Therefore it is proposed to leave it out.

For the discharges of wastewater from paper mills into marine waters and estuaries the TGD (EC2003B) assumes chemical/mechanical treatment for industrial discharges in coastal waters. Furthermore it is assumed that these discharges are diluted by a factor 100.

The available scenarios do not differentiate the process descriptions for continuous dosing (or frequent intermittent) and shock dosing.

5.5 Recommendation

To prevent confusion with respect to Emission Scenario Documents (ESDs) for several chemicals (including biocides) used in the paper industry, a description of the existing ESDs is given below.

There are three emission scenario documents that relate to the paper industry:

- ESD for chemicals used in pulp, paper and board industry:

This document relates to the chemicals industry category 12 and can be used for industrial chemicals used in the pulp, paper and board industry. (IC12 in TGD (EC2003A)):

- ESD for biocides in paper coating and finishing (BPT 6, 7 & 9 in TGD (EC2003B)):
This ESD should be used when dealing with biocides used as preservatives in paper coating and finishing (PT6, 7 and 9).
- ESD for biocides used in the paper and cardboard industry (PT12 slimicides):
This ESD (recommended in this report) should be used for biocides used as slimicides in the paper and board industry.

It is recommended to perform risk assessments for slimicides in papermaking mills with the following scenarios.

- A reasonable worst case scenario which is in line with the TGD (EC2003):
The RIVM/FEI-scenario for a paper mill with primary clarifier and chemical and mechanical treatment;
- A typical scenario:
The RIVM/FEI-scenario with primary clarifier and treatment in a WWTP (calculated with Simple Treat, TGD (EC2003B)).

This provides the possibility that certain slimicides only may be approved for use in paper mills that discharge their wastewater into a WWTP.

It should be taken into account that, due to variable use patterns of paper mill slimicides, it is necessary to consider the proposed instructions for use and make where relevant, separate calculations for continuous use, shock dose, etc, to cover all realistic worst case dosage patterns. In case of shock treatment it must be considered that the concentration in the water will not be levelled off much in the WWTP.

For emissions to the marine environment the RIVM/FEI-scenario for a paper mill with primary clarifier and chemical/mechanical treatment can be used. The TGD gives a dilution factor (100) for discharge into coastal waters.

Realistic worst case scenario

Typical case scenario

Figure 5.1 Realistic worst case scenario and typical case scenario for slimicides used in paper production processes

In Figure 5.1 the recommended scenarios are described from paper mill up to the concentration in the primary receiving compartments. For the reasonable worst case scenario this is the concentration in surface water, for the typical case this is the influent concentration in an industrial wastewater treatment plant (WWTP).

The tables 5.2, 5.3 and 5.4 contain the necessary input parameters and calculations for the recommended typical and worst case scenario.

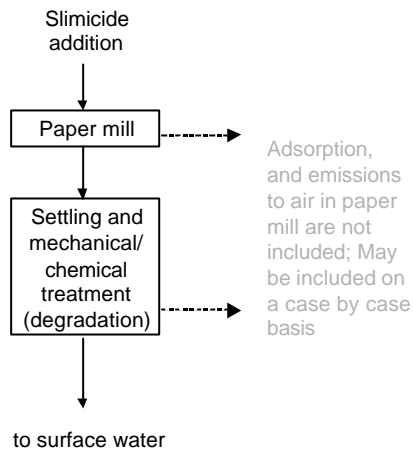
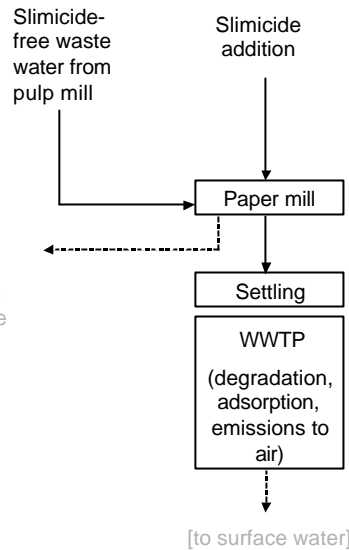
Three different dosage options are presented:

Option [A] automatically gives an average daily concentration in process water going to the wastewater treatment. Dosing is considered as a continuous process. The options [B] and [C] can be used for intermittent as well as continuous dosing. With intermittent dosing the concentrations before wastewater treatment will fluctuate, whereas with continuous dosing they will remain at a stable level which is determined by the degradation and loss processes as well as the hydraulic retention time. The calculations enable the determination of an average concentration or the concentration and release in time.

The scenarios include the impact of various pH conditions in the paper making process. These factors may be included on a case by case basis. According to the TGD (EC2003B), an evaporation of 10 % of the water in the dryer section of the paper machine occurs. The total of adsorption and emissions to air in the paper mill are taken to be 10%. It is not clear which amount of the slimicides in the evaporated water adsorbs to the dry paper and which amount evaporates together with the water. Yet it is logical to reason that also a total of 10 % of the slimicide will be lost via the dry-end processes, as there is no return flux to the wet-end from the dry-end.

Table 5.1 Common part of the models for the calculation of the theoretical average concentration (i.e. not including degradation) before wastewater treatment, depending on the way the dosage is expressed in the user's instructions:
 [A] amount of biocide per tonne of product: and
 [B/C] amount of biocide per m³ of water at the wire part of the paper machine.
 (modified from RIVM/FEI-scenario).

Variable/parameter	Unit	Symbol	Value	S/D/O/P
Input				
[A]				
Amount of biocidal product per tonne of dry paper according to user's instructions	[kg. tonne ⁻¹]	Q _{prod}		S
Amount of wastewater per tonne of dry paper	[m ³ . tonne ⁻¹]	WW	15	D
[B]				
Amount of biocidal product according to user's instructions	[kg.m ⁻³]	Q _{prod}		S
[A/B]				
Fraction of active ingredient in biocide preparation	[-]	F _{ai}		S
[B/C]				
Treatment of both long and short circulation with slimicide	[-]	APPL	yes or no	
Slimicide bearing fraction of the total wastewater flow coming from the short circulation of the wire part	[-]	F _{ww1}	APPL	
Typical case			yes: 0.6	P
Reasonable worst case			no: 1.0	P
Connection to pulp mill	[-]	CONN	yes or no	
Fraction dilution of slimicide-free wastewater with wastewater from pulping	[-]	F _{ww2}	CONN	
Typical case			yes: 0.5	P
Reasonable worst case			no: 0	P
[C]				
Concentration according to user's instructions	[g.m ⁻³]	C _{prod}		S
[A/B/C]				
Fraction of the slimicide that evaporates to air in the dry end of the papermaking machine	[-]	F _{air, paper}		S
Fraction adsorbed to the paper sheets in the dry end of the papermaking machine	[-]	F _{ads, paper}		S
OR: Total fraction of the slimicide lost in the dry end of the papermaking machine	[-]	F _{total loss, paper}	0.1	D
Output				
Dose of a.i. dependent on specifications for the amount of biocide preparation (Q _{prod})	see calculations	DOSE _{ai}		
Theoretical concentration (i.e. assuming	[g.m ⁻³]	C _{paper}		

Variable/parameter	Unit	Symbol	Value	S/D/O/P
no degradation) before wastewater treatment (kg.m ⁻³)				
Calculations ¹⁾				Unit
$F_{\text{total loss, paper}} = F_{\text{air, paper}} + F_{\text{ads, paper}}$ or default				[-]
[A] $\text{DOSE}_{\text{ai}} = Q_{\text{prod}} * F_{\text{ai}}$				[kg. tonne of paper ⁻¹]
$C_{\text{paper}} = \text{DOSE}_{\text{ai}} / \text{WW} * 1000 * (1 - F_{\text{total loss paper}})$				[g. m ⁻³]
[B] $\text{DOSE}_{\text{ai}} = Q_{\text{prod}} * F_{\text{ai}}$				[kg. m ⁻³ at the wire part]
$C_{\text{paper}} = \text{DOSE}_{\text{ai}} * F_{\text{ww1}} * (1 - F_{\text{ww2}}) * 1000 * (1 - F_{\text{total loss, paper}})$				[g. m ⁻³]
[C] $C_{\text{paper}} = C_{\text{prod}} * F_{\text{ww1}} * (1 - F_{\text{ww2}}) * (1 - F_{\text{total loss, paper}})$				[g. m ⁻³]

1) Table A does not have the possibility of input for all dosages that might be found in the user's instructions. However the data can be converted easily using the calculations as presented in Table 4.2.

Table 5.2 Common part for the emission scenarios for calculating the release of slimicides in paper mills taking degradation into account (modified from RIVM/FEI -scenario). Degradation includes hydrolysis during the papermaking process as well as during water treatment; biodegradation may occur during water treatment; other degradation processes are not excluded. Different pHs in the process may be taken into account.

Variable/parameter	Unit	Symbol	Value	S/D/O/P
Input				
Half-life for degradation during paper production process	[d]	DT50deg1		S
Half-life for degradation during settling and chemical/ mechanical water treatment	[d]	DT50deg2		S
Output				
Rate constant for hydrolysis under different process conditions (pH ~5, pH~7, pH~8)	[d ⁻¹]	kdeg1		
Rate constant for degradation during water treatment (hydrolysis and biodegradation)	[d ⁻¹]	kdeg2		
Calculations				
General form:				
$k_{\text{deg}} = \ln 2 / \text{DT50}$				

Table 5.3 Model for the calculation of the relevant effluent concentrations. Concentration reductions are due to degradation in process water and during water treatment (see figure 5.2) (modified from RIVM/FEI -scenario)

Variable/parameter	Unit	Symbol	Value	S/D/O/P
Input				
Theoretical concentration of a.i.	[g.m ⁻³]	C _{paper}		O
Hydraulic retention time for paper making process	[d]	T _{pr}	0.167	D
Hydraulic retention time for	[d]	T _{treat}	0.167	D

Variable/parameter	Unit	Symbol	Value	S/D/O/P
primary settling and chemical/mechanical treatment				
Time elapsed since dosing event	[d]	t		S
Time interval between dosing	[d]	T _{int}		S
Fraction of the slimicide adsorbed to particles during primary settling	[-]	F _{ads, settling}	0	D
Fraction of the slimicide adsorbed to particles during chemical and mechanical treatment	[-]	F _{ads, cm}	0	D
Output				
Concentration in influent to the primary settler (various conditions)	[mg. l ⁻¹]	C _{infl-ps}		
Concentration in effluent of water treatment system	[mg. l ⁻¹]	C _{local, effl-treat}		
Concentration in influent to WWTP	[mg. l ⁻¹]	C _{local, infl-WWTP}		

Calculations for the reasonable worst case scenario:

[A] (Semi-)continuous dosing or frequent intermittent

$$C_{infl-ps} = C_{paper} / (1 + kdeg1 * Tpr)$$

[B] and [C] Shock dose or infrequent intermittent dosing

after one dosing

$$C_{infl-ps} = C_{paper} * e^{-kdeg1 * t}$$

after n dosings at intervals of T_{int}

$$C_{infl-ps} = \sum_{i=1}^n C_{paper} * e^{-(t - (i-1) * Tint) * kdeg1} \quad \text{for } (t - (i-1) * Tint) > 0$$

$$C_{local, effl-treat} = C_{infl-ps} * (1 - F_{ads, settling} - F_{ads, cm}) * e^{-kdeg2 * Ttreat}$$

Calculations for the typical case scenario:

$$C_{local, infl-WWTP} = C_{paper} * (1 - F_{ads, settling}) * e^{-kdeg1 * Tpr}$$

6 OIL INDUSTRY

6.1 Description of industry or use area

In oil and gas production processes slimicides are used for the preservation of drilling muds. The presence of microorganisms in drilling mud causes slime formation, which may lead to clogged filters (Source: Paulus, 1993 in INFU2000). Particularly pentadial (glutaraldehyde) is used for this application (COWI2001). Similar biocidal products are sometimes also added to the seawater pumped into the drilling hole but these are considered to belong to process water preservatives (PT 11) and were not specifically included in this scenario. However, the oil extraction scenario may also be relevant for their emission estimation.

6.2 Identification of the points of application and release for slimicides used by the oil extraction industry

The life cycle of slimicides used in the drilling process is presented in figure 6.1 (Source: COWI2001).

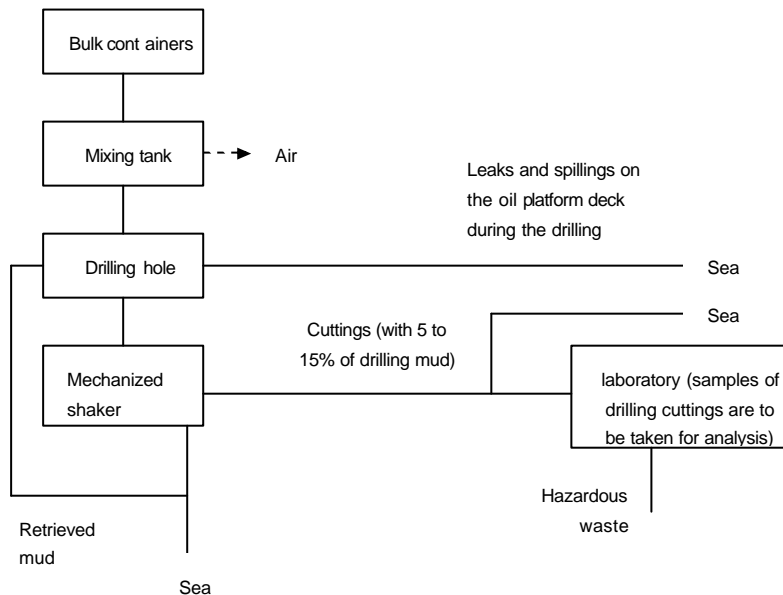

Figure 6.1 Process of oil and gas extraction (Source COWI2001)

Slimicides in the oil extraction processes are used for control of slime forming microorganisms in water-based drilling mud. This mud is composed of water, clay and additives meeting precise specifications.

Drilling mud is pumped down in the drilling tube and comes to the surface again between the tube and the drilling hole. Drilling mud functions are lubricant for the drill head and transport of the cuttings to the surface. Drilling mud also provides the hydro-static pressure that prevents collapse of the drilling hole.

Slimicides are added to the drilling mud during the production of the mud to preserve it during storage.

Slimicides from bulk containers are usually added to the drilling mud in closed systems. The mixing of the mud chemicals, including biocides, may take place in open tanks on the drilling rigs. The open tank system may cause aerosol formation, but as no splashing occurs this is not likely to happen.

Normally no washing of the bulk containers is necessary because the biocides are transported in specific bulk containers that are normally used for one specific biocide. Under special circumstances such as changing the biocidal chemical or facing logistic transportation problems, bulk containers may be washed and the water discharged.

No simple default values can be presented for the application phase of drilling. The amount, composition and place of formulation of drilling mud vary between companies and geological conditions.

Drilling mud is added to the drilling line through a closed system. When the used drilling mud reappears at the surface after being down in the drilling hole, cuttings are separated from the mud in a mechanical shaker system. This is an open system with the possibility of evaporation and splashing. It is not possible to separate the drilling cuttings and the drilling mud very efficiently, and between 5 and 15 % by weight of the discharged cuttings is mud. This can amount to 50% of the total amount of the drilling mud used.

Retrieved mud, without drilling cuttings, is either recirculated back into the drilling line together with new drilling mud or discharged if the drilling operation requires a new type of drilling mud.

During the drilling process drilling mud will also be spilled on the rig deck, which will be flushed to the sea. When drilling, samples of drilling cuttings are to be taken for analysis. The samples are contaminated with drilling mud. It should be noted that the size of the cutting samples is small, but the number of samples may be large. These samples finally end up in chemical waste.

Generally, all biocides used in water-based drilling mud are discharged to sea, either during the use phase or the disposal phase. In the use phase, when discharging cuttings to sea, the adherent drilling mud will be discharged as well.

As a new approach, some chemical suppliers are presently testing the possibility of taking the used drilling mud onshore for cleaning and reuse. In some exceptional cases the drilling mud and the cuttings are re-injected into the reservoir.

(Source: COWI2001)

6.3 Emission scenario for SLIMICIDES IN OIL EXTRACTION PROCESSES

6.3.1 Description of available scenario for slimicides used in oil extraction processes

The CHARM (Chemical Hazard Assessment and Risk Management) model contains a scenario for oil drilling operations. It was developed in close co-operation between the exploration and production (E&P) industry, chemical suppliers and authorities of some of the countries party to the Oslo and Paris conventions (CHARM2001).

The CHARM model calculates the discharged amount and the concentration of a specific chemical in the receiving marine water and in the sediment. The model is based on default parameters for standard North Sea oil and gas platforms based on information provided by national authorities on conditions at existing platforms. Since the standard platforms are meant to represent the 'realistic worst case' situation, the 95 percentile values on these existing North Sea platforms were chosen. The model requires input of a number of parameters for the specific chemical. Various parts of the model have been validated in experimental programmes.

The CHARM model is to be applied for operational discharges of chemicals in the process of drilling, completion and production under 'realistic worst case' conditions. Potential risks during the transport of chemicals, handling of unused materials, discharges due to calamities and other discharges of a platform (such as air emissions or sanitary waste discharges) are not considered by this model. In this report only the slimicide containing water-based drilling mud (WBM) is considered.

In the CHARM-model, drilling muds are assumed to be discharged in two modes:

1. "Continuous" discharges of mud adhering to the drilled cuttings. Continuous discharge is in fact not a correct name, because the discharges tend to be intermittent. The rate of discharge will usually be small and the material will be dispersed and diluted almost immediately.
2. "Batchwise" discharges occur during drilling operations when the mud needs to be diluted. Some of the mud system may have to be discharged and the remainder of the system diluted. Batchwise discharges also occur at the end of a section where a new or different mud will be required in the next section. Finally, these discharges will also occur at the end of the well drilling when all operations are finished and the rig is to be moved to a new location. These discharges are larger both in volume and rate of discharge.

Although the highest concentrations are caused by batchwise discharges, both pathways are assessed in the CHARM model, because the concentration in the sediment around the drilling platform is only calculated for continuous discharges. Within CHARM the offshore environment is divided into two compartments: marine water and sediment. This is done in order to acknowledge the fact that a chemical present in the environment will partition between the water and organic matrix in the sediment. Consequently, two PEC values are calculated: PEC_{water} and PEC_{sediment} .

The amount of a certain additive present in the mud-system (further referred to as dosage) can be expressed as a weight percentage or as a concentration (the common unit being pounds per barrel: ppb). The first step in the calculations is, therefore, to use this dosage together with the volume of mud discharged (either continuous or batchwise) to calculate the amount of additive discharged (see table 6.1). To derive the regional water concentration of an additive for **continuously** discharged mud, the amount of additive discharged is divided by the volume of water (during the period of discharge) in which it is diluted. To take into account other platforms in the area which might also contribute to the regional concentration of a chemical, the water available for dilution is limited to the fixed area per platform, defined by the standard platform density of one platform per 10 square kilometres. This dilution is enhanced by the residual current, which leads to refreshment of the water in the area.

The dilution characteristics of **batchwise** discharges differ significantly from those of continuous discharges, due to the increased discharge rates (i.e., 600 m³ per 16 days or 1.56 m³.h⁻¹ for continuous discharge and 375 m³/h⁻¹ for batchwise discharges (from: CIN Expert Group on Drilling Chemicals, 1998). For batchwise discharges a look-up table of dilution factors is given. The dilution factor is a function of the actual discharge volume, the density and the discharge rate. The table is based on the results of a detailed chemical dispersion model. The default factor selected for batchwise dilution at 500 m from the source is 1:13,000. This represents a 'worst case' approach (highest discharge rate, highest density).

The process of sediment-water partitioning of drilling chemicals is only considered for continuous discharges. The concentration for batchwise discharges is not used for this partitioning, since it is only present for a short period of time, while the partitioning calculations assume an equilibrium situation. The regional concentration used for the partitioning is thus represented by PEC_{water,cont}.

6.3.2 Overview of method

In the original source document for the emission scenario for slimicides used at oil drilling processes calculations was provided. The original method is presented in appendix 1 of this document.

The calculation method, in a standard notation and format, is given in table 6.1.

Table 6.1 Emission scenario for calculating the releases from slimicides used in oil drilling processes (CHARM2001)

Variable/parameter	Unit	Symbol	Value	S/D/O/P
Input				
[A]				
Fraction of the a.i. in the mud	[-]	F _{ai,mud}		S
Density of the discharged mud	[kg. m ⁻³]	RHO _{mud}	Section ¹⁾ : 17.5": 1400 12.25": 1600 8.5": 1600	D
[B]				
Dosage of the a.i. in the mud	[pounds per barrel]	DOSE _{ai,mud}		S
Conversion constant from pounds per barrel to kg.m ⁻³	[kg. barrel. m ⁻³ . pounds ⁻¹]	Fconv	2.85	D ^c
[A/B]				
Volume of mud discharged for specific section	[m ³]	V _{mud, discharged}	Continuous Section ¹⁾ : 17.5": 600 12.25": 450 8.5": 250 Batchwise Section: 12.25": 375 8.5": 280	D

Variable/parameter	Unit	Symbol	Value	S/D/O/P
Number of platforms per square kilometre	[km ²]	N _{platform}	0.1	D
Average water depth around the platform	[m]	Depthlocal_wway	150	D
Fraction of sea water refreshed in the receiving volume around the platform per day	[d ⁻¹]	F _{repl,water}	0.24	D
Time needed to drill a section	[d]	T _{drilling}	16	D
Dilution factor for batchwise discharges (selected default)	[-]	DILUTION _{batch}	13000	D
Sediment-water partition coefficient	[l. kg ⁻¹]	Kp		S
Fraction of a substance in sediment that is degraded in 1 year	[-]	Fdegrad		S

Output:

Volume of ambient water per platform available as diluent	[m ³]	V _{water,platform}	
Volume of water passing the platform	[m ³ .d ⁻¹]	Q _{repl,water}	
Emission: amount of a.i. discharged	[kg]	E _{a.i., discharged}	
Predicted Environmental Concentration in marine water for continuous discharges of a.i. in WBM	[mg.l ⁻¹]	PEC _{water,cont}	
Predicted Environmental Concentration in marine water for batchwise discharges of a.i. in WBM	[mg.l ⁻¹]	PEC _{water,batch}	
Predicted Environmental Concentration in marine sediment for continuous discharges of a.i. in WBM	[mg.kg ⁻¹]	PEC _{sediment,cont.}	

Intermediate calculations:

Amount of a.i. discharged (kg):

$$V_{\text{water,platform}} = 1 / N_{\text{platform}} * \text{Depthlocal_wway} * 10^6$$

$$Q_{\text{repl,water}} = V_{\text{water,platform}} * F_{\text{repl,water}}$$

$$[A] E_{\text{a.i.,discharged}} = F_{\text{a.i.,mud}} * V_{\text{mud,discharged}} * \text{RHO}_{\text{mud}}$$

$$[B] E_{\text{a.i.,discharged}} = \text{DOSE}_{\text{a.i.,mud}} * V_{\text{mud,discharged}} * F_{\text{conv.}}$$

End calculations:

$$\text{PEC}_{\text{water,cont}} = (E_{\text{a.i.,discharged}} / (T_{\text{drilling}} * Q_{\text{repl,water}})) * 10^3$$

$$\text{PEC}_{\text{water,batch}} = (E_{\text{a.i.,discharged}} / V_{\text{mud,discharged}}) / \text{DILUTION}_{\text{batch}} * 10^3$$

$$\text{PEC}_{\text{sediment}} = \text{PEC}_{\text{water,cont.}} * Kp * (1 - F_{\text{degrad}})$$

- 1) The drilling well is divided in different drilling sections (vertical division). Every section equals a layer of soil or rock with specific characteristics. The diameter of the section is shown in inches (").

6.3.3 Discussion of the method

Dimensions and characteristics of the point sources and receiving environmental compartments

The scenario is developed in co-operation with industry, suppliers and authorities of several European countries. On the basis of information from these groups a standard platform with receiving compartment marine water with well-founded dimensions and parameters was defined as a 'realistic worst case', see table 8.2 and figure 6.2. The standard platform density is one platform per 10 km². To take into account that other platforms in the area might also contribute to the regional concentration of a chemical, the water available for dilution is limited to the fixed area per platform.

Table 8.2. Default values for the standard platform (95-percentile values of existing North Sea oil and gas platforms to represent the 'realistic worst case')

Parameter	Value
CHARM (discharge at open sea)	
Platform density	1 per 10 km ²
Water depth	150 m for oil (40 m for gas)
Local area	circle with 500 m radius
Local water volume	$[\pi * 500^2 * 150 = 1.18 * 10^8 \text{ m}^3$ but no assumption of complete mixing]
Regional water volume	$10 * 10^6 * 150 = 15 * 10^8 \text{ m}^3$
Refreshment rate of the water	0.24 d ⁻¹
Refreshment water volume	$3.6 * 10^8 \text{ m}^3 \cdot \text{d}^{-1}$
EU TGD Marine environment (discharge from land to coastal area)	
Local water volume for dilution (coastal areas)	200,000 m ³ (derived from 1:100 dilution of STP effluents)
Regional water volume surface area	400 km ² (=40 km * 10 km)
Water depth	10 m
Regional water volume	$40 * 10^6 \text{ m}^3$

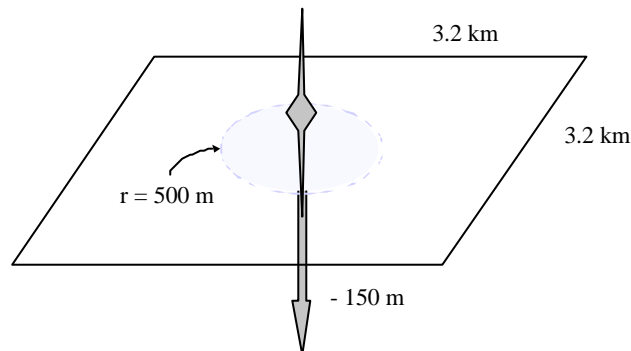

Figure 6.2. Comparison of local and regional scale for oil platforms in the CHARM model

Within the new Technical Guidance Document (EC 2003) an approach for the marine risk assessment has been developed including the description of the dimensions of the local and a regional compartments. These are included in table 8.2. As shown in the table, the local scenarios vary between CHARM and the EU TGD, but a strict comparison cannot be made as the (batchwise) dilution within CHARM is not achieved by complete mixing as in the EU TGD marine scenario. The

obvious difference is the depth (10 versus 150 m). The differences for the regional scenario are relatively small, within a factor of 3.

The scenarios cannot be compared on the basis of the dilution factors, because different sizes are used for the receiving compartments. For a continuous discharge in CHARM, the water available for dilution is limited to the fixed area per platform. This dilution is enhanced by the residual current, which leads to refreshment of the water in the area. The dilution characteristics of batchwise discharges differ significantly from those of continuous discharges, due to the increased discharge rates (for continuous discharges $1.56 \text{ m}^3 \cdot \text{hr}^{-1}$ and for batchwise discharges $375 \text{ m}^3 \cdot \text{hr}^{-1}$). These dilution factors have been empirically derived. Therefore these dilution factors can not be compared to the 1:100 applied in the EU TGD for the effluent of an STP (discharge $83 \text{ m}^3 \cdot \text{hr}^{-1}$).

The dimensions of this standard platform and receiving compartment are based on the situation in the North Sea region and, according to [CHARM 2001], are considered a realistic worst case for the North East Atlantic ocean. The processes in other regions are not expected to differ greatly between regions, so emissions may be similar. The level of conservatism is then determined by the comparability of the dimensions in the other regions (depth of the water, density of the platforms). These are values that may be set in the calculations.

A relevant difference is the way the background concentrations are taken into account. In CHARM the refreshment water passing the platform is coming from one platform (thus the background concentration is zero) whereas in the TGD the local environment is nested into the regional including a background concentration caused by other platforms in the same oilfield.

Degradation

Degradation in the water phase is not considered in the CHARM-model.

Biodegradation will most probably not be important. Depending on the time the drilling mud is in use, hydrolysis may be of importance. The chemical that is normally used in oil drilling processes is glutaraldehyde (see chapter 6.1). Glutaraldehyde is stable at pH5 and 7 (DT50: 100-500 d). At pH9 it hydrolyses to some extent (DT50: 46 days or 13% in 2-4 days). According to these data, it can be concluded that hydrolysis is not important for glutaraldehyde.

If under the conditions of the open sea, degradation is judged to be a relevant process, this may be added on a case by case basis.

Other emission routes

Emissions other than those from the drilling mud discharged with the drilling cuttings (continuous) and the discharge of used mud (batch) are not considered in the CHARM-scenario.

Emissions that may take place during the phase of application, e.g. spills or washing of bulk containers are considered negligible in COWI2001. Handling of the drilling line may also cause spills on the rig deck. The mud on the drilling rig is subsequently discharged after deck wash. The amount of releases caused by spills is assumed minimal compared with the amount of mud used and the mud discharged with the cuttings (COWI2001).

Possible emissions to air, e.g. from aerosol formation in open application systems or from spills on the deck of the oil platform are not considered. The Henry's Law constant for glutaraldehyde, the biocide that is normally used in oil drilling

processes, is $2.4 \cdot 10^8 \text{ atm} \cdot \text{m}^3 \cdot \text{mol}^{-1}$ (SRC EpiWin estimate). Based on this value, emissions of glutaraldehyde to air are considered negligible. The scenario also does not consider loss in porous formations. It is assumed that cuttings or mud are not re-injected into the well.

6.3.4 Conclusion

The TGD [EC2003] allows for the use of more precise information in 'site specific' assessments. For substances released from offshore platforms it is noted that 'a harmonised mandatory control system for the use and reduction of the discharge of offshore chemicals is already agreed within OSPAR (OSPAR 2000a, 2000b). For this specific exposure situation within the EU legislation, the methodology proposed by OSPAR can be taken into consideration'. It is added that 'the methodology for assessing releases from platforms (e.g. CHARM-model) that has been developed in the context of these OSPAR decisions was not re-discussed in the context of the development of the present guidance document for marine risk assessment.'

The EUBEES working group considers the emission estimations according to the CHARM method to be applicable for the estimation of emissions of slimicides from oil platforms. Several parameters of the assessment of environmental distribution (eg. dimensions of the receiving compartment) were discussed and they may be reviewed in a later stage on the basis of relevant data and evaluations. In the mean time this assessment can also be done according to the CHARM method.

PM

The EDTA scenario was checked. They first use the 1:10 dilution in process water (1 well out of 10), next a 1:10 for dilution into the aquatic environment (standard TGD). As an alternative to 1:10 from the TGD they use a dilution factor of 1000 for batchwise dilution from CHARM. This figure is for a different type of chemicals (not in Water Based Muds), therefore a different use volume, discharge rate and density.

7 REFERENCES

- [RIVM2001] National Institute of Public Health and the Environment (RIVM), Finnish environment Institute (FEI), Emission Scenario Document for biocidal products applied in the paper and cardboard industry (draft RIVM report)
- [SNCI1995] National Chemicals Inspectorate, Sweden, Eriksson, U., A. Johnson, M. Törnlund: Risk Assessment of Slimicides (1995)
- [INFU2000] Institute for Environmental Research (INFU), University of Dortmund, UBA Berlin: Gathering and review of Environmental Emission Scenarios for biocides (2000)
- [CHARM2001] User guide for the evaluation of chemicals used and discharged offshore version 1.2: A cin revised charm III report 2001: Henriquez, L.R., C.C. Karman, M. Robson, M. Thatcher
- [COWI2001] COWI and CETOX: Biocide Use in Denmark Phase 2, Preliminary Assessment of Human and Environmental Exposure (2001)
- [OECD2002] OECD Environmental Health and Safety Publications: Emission scenario document on water treatment chemicals (2002), Environment Directorate, Organisation for Economic Co-operation and Development
- [EC2003] European Commission: Technical Guidance Document (TGD) in support of Commission Directive 93/67/EEC on risk assessment for new notified substances and commission regulation (EC) No. 1488/94 on risk assessment for existing substances and directive 98/8/EC of the European parliament and of the council concerning the placing of biocidal products on the market part IV (2003)
- [EC2003A] Emission scenario Document IC-12. Pulp, paper and board industry. Assessment of the environmental release of chemicals used in the pulp, paper and board industry.
- [EC2003B] Emission scenario Document BPT 6,7 & 9. Biocides used as preservatives in various applications. Emission scenario document for biocides used in paper coating and finishing
- [SIRKKA2001] Finnish Environment Institute, Sirkka, S., Environmental exposure assessment of slimicides (2001)
- [ECO2000] Finnish Environment Institute, Koponen, K., Ecotoxicological risk assessment of actide PT (2000)
- [BAUR2002] Rohm and Haas Company, Paper-mill model for slimicides.(2002)
- [CAN2003] Crechum Technologies Inc, Chemical releases from Canadian Pulp and Paper Mills, Draft report (2003)
- [OSPAR2000a] Decision 2000/2 on a Harmonised Mandatory Control System for the Use and Reduction of the discharge of Offshore Chemicals.
- [OSPAR2000b] Decision 2000/3 on the Use of Organic Phase Drilling Fluids and the discharge of OPF-contaminated cuttings.
- [WEBER1972] Weber Jr, W.J., 1972. Physicochemical processes for water quality control. Wiley-Interscience Series of Texts and Monographs. Wiley & Sons, Inc. ISBN 0-471-92435-0.

Appendix 1: The original descriptions of methods

SNCI-scenarios

Scenario 1 - Fine paper mill

Total water consumption is 5,000 m³/day.
The volume of white water circuit is 300 m³.
Dosage 15 minutes every 12th hour (two times/day) to recommended concentration in the white water. The total amount of active ingredient per day is calculated.
The average retention time in the white water is about 40 minutes at 50°C and pH 4.5.
The average retention time in the clarifier (sedimentation & chemical precipitation) is about 20 hours at 35°C and pH 7.
Hydrolysis is of importance. The hydrolysis rate at 35°C is assumed to be twice as rapid as at room temperature. The distribution to sludge is estimated from results of USES, fugacity model, level III (Mackay).

Scenario 2 - Newspaper mill (about 2 days retention time)

Total water consumption is 25,000 m³/day.
The volume of white water circuit is 1,000 m³.
Dosage 15 minutes every 12th hour (two times/day) to recommended concentration in the white water. The total amount of active ingredient per day is calculated.
The average retention time in the white water is about 60 minutes at 50°C and pH 4.5.
The average retention time in the primary clarifier (sedimentation) is about 12 hours at 35°C and pH 7. Hydrolysis is of importance. The hydrolysis rate at 35°C is assumed to be twice as rapid as at room temperature.
The average retention time in the aerated basin is about 20 hours at 30°C and pH 7.
Biotic degradation and/or hydrolysis are/is of importance. The degradation rate in the aerated basin is assumed to be the same as in inherent biodegradability studies, but twice as high compared with biotic degradation studies with water/sediment-systems without adapted microorganisms.
The average retention time in the secondary clarifier (sedimentation & chemical precipitation) is about 15 hours at 25°C and pH 7. Hydrolysis is of importance.
The distribution to sludge is estimated from results of USES, fugacity model, level III (Mackay).

Scenario 3 - Newspaper mill (about 1 day retention time)

Total water consumption is 28,000 m³/day.
The volume of white water circuit is 300 m³.
Dosage 15 minutes every 12th hour (two times/day) to recommended concentration in the white water. The total amount of active ingredient per day is calculated.
The average retention time in the white water is about 20 minutes at 50°C and pH 4.5.
The average retention time in the primary clarifier (sedimentation) is about 5 hours at 35°C and pH 7. Hydrolysis is of importance. The hydrolysis rate at 35°C is assumed to be twice as rapid as at room temperature.
The average retention time in the aerated basin is about 12 hours at 30°C and pH 7.
Biotic degradation and/or hydrolysis are/is of importance. The degradation rate in the aerated basin is assumed to be the same as in inherent biodegradability studies, but twice as high compared with biotic degradation studies with water/sediment-systems without adapted microorganisms.

The average retention time in the secondary clarifier (sedimentation & chemical precipitation) is about 5 hours at 25°C and pH 7. Hydrolysis is of importance. The distribution to sludge is estimated from results of USES, fugacity model, level III (Mackay).

The predicted environmental concentration, PEC, is also stated in the tables assuming a dilution factor of 100.

Calculations of the dissipation of the active metabolites of bromochloro-5,5-dimethylhydantoin (BCDMH)

The half life of the decay of chlorine and bromine induced oxidants is assumed to be between 10 minutes and 3 hours divided in the following three different phases of dissipation: The first phase with a dissipation rate k of 0.06 min^{-1} during 15 minutes, the second phase with a dissipation rate k of 0.014 min^{-1} during 190 minutes and the third phase with a dissipation rate k of 0.004 min^{-1} .

An example of the calculation of the concentration of oxidants in the paper mill effluent is described below for scenario 1:

Dosage 2 g/m^3 in $300 \text{ m}^3 \rightarrow 600 \text{ g/dosage} \rightarrow 1200 \text{ g/day}$
 Concentration before decay = $1200/5000 \text{ g/m}^3 = 0.24 \text{ mg/l}$.

Retention time in the white water: 40 minutes.

Retention time in the clarifier: 20 hours \rightarrow 1200 minutes.

Dissipation rate: 1st phase $k=0.06 \text{ min}^{-1}$ during 15 min. 2nd phase $k=0.014 \text{ min}^{-1}$ during 190 min. 3rd phase $k=0.004 \text{ min}^{-1}$.

Concentration after the white water: $C=0.24 \cdot e^{-0.06 \cdot 15} = 0.098 \text{ mg/l}$ (after the 1st phase),

$C=0.098 \cdot e^{-0.014 \cdot 25} = 0.069 \text{ mg/l}$. Left of the time in the 2nd phase is (190-25) 165 min.

Concentration after the 2nd phase in the clarifier: $C=69 \cdot e^{-0.014 \cdot 165} = 6.8 \text{ } \mu\text{g/l}$.

Left of the time in the clarifier: 1035 min.

Concentration after the clarifier: $C=6.8 \cdot e^{-0.004 \cdot 1035} = 0.11 \text{ } \mu\text{g/l}$

$\rightarrow 0.11 \text{ } \mu\text{g halogens/l}$ in the papermill effluent.

If the dilution factor is assumed to be 100 \rightarrow PEC=1.1 ng/l

USES-scenario

Existing and produced emission models

12.1 Paper/cardboard (Luttik et al., 1993)

From Luttik et al. A model was developed for the Netherlands paper and cardboard industry. The production volume lies between 20.000 and 200.000 tons per year.

In many cases paper and cardboard producers have their own STP.

In the scenario an industrial STP is used, because the water consumption lies between 800 m³ – 11.000 m³ per day. The default value of the flow equal to the waste quantities is 3000 m³ per day.

Parameter/variable (unit)	Symbol	Default	C/R/E/O
Input:			
Quantity of water discharged per day (m ³ /day)	Q _{water}	3000	R/E
Concentration of a.i. in process water discharged (mg/l)	C _{a.i.}		R
Quantity of water in STP (m ³ /day)	Q _{STP}	3000	R/E
Dilution factor of receiving surface water (-)	F _{dilut}	10	E(D)
Output:			
Concentration of a.i. receiving surface water (mg/l)	C _{surf}		

Model calculations:

L_{wwt} Quantity of a.i. totally released w. waste water (kg/day)

$$= Q_{\text{water}} * C_{\text{a.i.}} * 10^{-3}$$

R_{STP}: Fraction removed by STP Calculation by standard module of USES

$$C_{\text{surf}} = L_{\text{wwt}} / Q_{\text{STP}} * R_{\text{STP}} / F_{\text{dilut}} * 10^3$$

C= constant (if possible the contents are presented)

R= (Required) values from the test results in the notification of a biocide

E= Expert estimations (if possible the expert estimations (defaults) are presented)

O= Output from previous modules/calculations

RIVM/FEI-scenario

Contents

SUMMARY

1. INTRODUCTION
2. BIOCIDES AND ACTIVE INGREDIENTS
3. DOSAGE AND CONCENTRATION OF THE BIOCIDES
4. MODEL FOR THE FINNISH SCENARIOS
 - 4.1 Rate constants for degradation
 - 4.2 New paper mill model

Summary

Slimicides are biocidal products which are applied in various branches of industry used to control slime-producing micro-organisms in industrial processes. They belong to product-type 12 (Slimicides) according to the Directive concerning the placing biocidal products on the market (EC, 1998). The main industries where slimicides are used in processes are pulp and paper industry, and oil industry (secondary oil recovery). This report focuses on slimicides intended for use in paper and cardboard manufacturing exclusively. Several models for the environmental exposure assessment of biocides in paper and cardboard industry have been presented already. A Dutch paper slimicide assessment model has been implemented in USES 1.0, 2.0 and 3.0 (Uniform System for the Evaluation of Substances). A similar Finnish spreadsheet calculation model with two scenarios is also available. The default values for parameters such as amount of wastewater for Finnish paper mills may be quite different for the Dutch situation. The Finnish scenarios also take degradation due to photolysis, hydrolysis and biodegradation into account.

The process and effluent concentrations of slimicides vary a lot depending on the processes and manufacturing conditions in different mills (e.g. due to different pH or degree of closure of the paper making process). The paper making processes have been significantly modified in the last ten years. In this report, the available environmental exposure calculation models used in the environmental exposure assessment of slimicides are reviewed and updated.

Two calculation methods can be followed in the risk assessment of slimicides. First, the standard STP model of EUSES (European Union System for the Evaluation of Substances) may be used (with 3000 m³ wastewater per day) and second, a model with the two scenarios of Finland. This report elaborates the Finnish scenarios in the way of EUSES and USES. In this report also an addendum is given to the existing model present in USES. It comprises the calculation of the concentration of the slimicide in the process water of the paper mill before wastewater treatment depending on the user's instructions. The two scenarios introduced in this report are based on the instructions as well. Furthermore, hydrolysis and biodegradation are taken into account. The new emission scenarios are presented in tables with the input and output data, and calculations specified.

Some symbols and descriptors in the emission scenarios occur already in EUSES. New symbols have been generated in accordance with Van der Poel (2000).

In the paper and cardboard industry preservatives are used for the preservation of pulp in the paper machine. These biocidal products belong to product-type 9 (Fibre, leather, rubber and polymerised materials preservatives). The subject is discussed in Chapter 5 and it is proposed to use the slimicide emission scenario also for this application.

1 Introduction

Slimicides are biocides used to control slime-producing micro-organisms in industrial processes. Especially in systems where process water is recycled with a high degree of closure of the system slime formation is a serious problem. Biocides applied in process cooling water systems to control the slime-producing micro-organisms are referred to as product-type 11 (Preservatives for liquid-cooling and processing systems) (EC, 1998) and are therefore not regarded in this report. Furthermore, a simple model already has been developed (Luttik *et al.*, 1993). Slimicides belong to product-type 12 (Slimicides) (EC, 1998). The main industries where slimicides are used in processes are pulp- and paper industry, and oil industry (secondary oil recovery) (Eriksson and Johnson, 1996; Van Dokkum *et al.*, 1998). This report focuses on slimicides intended for use in paper and cardboard manufacturing exclusively.

In Chapter 3 of Luttik, *et al.* (1993) a model for the assessment of biocides in paper and cardboard industry has been presented already. This model has been implemented in USES 1.0, 2.0 and 3.0, and will be maintained for the time being, i.e. assuming a paper mill producing paper/cardboard with an amount of 3000 m³.d⁻¹ wastewater, which is discharged to a private STP of the same size.

The Finnish Environment Institute developed environmental exposure assessment scenarios for slimicides when it started risk assessment in 1993. The scenarios were based on assumptions and parameters from typical Finnish paper mills in the late 1970s and 1980s (Braunschweiler, 1993a, 1993b). Later, the scenario models were developed more detailed and transformed to MS Excel spreadsheet calculations to be used in the exposure assessments (Seppälä, 1997). In a summary report (FEI, 1999) the equations for calculations for PECs (Predicted Environmental Concentrations) for two slimicide scenarios together with two Excel files with calculations, are supplied. Recently, the slimicide scenarios have been updated according to changes in paper making practices (Sirikka, 2001). Nowadays, water circulation systems are more closed and many acid processes have been changed to either neutral or slightly alkaline.

The (default) values for parameters such as amount of wastewater for Finnish – and e.g. Swedish – paper mills may be quite different for the Dutch situation. The Finnish scenarios also take degradation due to photolysis and hydrolysis into account. The process and effluent concentrations of slimicides vary a lot depending on the processes and manufacturing conditions in different mills. For example, the process may occur at a lowered pH value of 5 or at neutral or slight alkaline (pH=8) conditions and there may or may not be a closure of the process water (i.e. recirculation of process water and where a relatively large fraction of the wastewater comes from the wire part in the paper machine) (Sirikka, 2001).

So, two ways can be followed in the risk assessment of slimicides. Firstly, the standard STP model of EUSES may be used (with 3000 m³ wastewater per day) and secondly, a model with the two scenarios of Finland. This report elaborates the Finnish scenarios in the way of EUSES and USES.

In this report also an addendum is given to the existing model present in USES and described in Luttik, *et al.* (1993). It comprises the calculation of the (average) concentration of the slimicide in the process water of the paper mill before wastewater treatment, depending on the user's instructions. Usually the instructions give either an amount of biocide per tonne of dry paper or an amount of biocide per quantity of process water. The two scenarios introduced in this report are based on these types of instructions as well. The concentrations calculated are the theoretical concentrations assuming that no degradation has occurred during the paper making process. They are the starting points in the calculation of the PEC. However, hydrolysis and biodegradation after the paper making

process are taken into account. Furthermore, hydrolysis and some biodegradation occur also in the process water and this can be taken into account as presented in the Finnish scenarios.

It should be noted that it holds for a number of biocides used in aqueous solutions the biocidal activity does not come from the active ingredient itself but from a substance released from the biocide due to hydrolysis. In such cases the risk assessment may fall into two distinct parts. Firstly, the original biocide as such is assessed, taking into account the depletion due to hydrolysis. Secondly, an assessment is carried out for the substance – i.e. the actual active ingredient – released. The ecotoxicological data for this substance have to be used and a correction should be made for the concentration. This is elucidated with the following example of a fictitious biocide. One molecule of the biocide – with a molecular weight of 240 – yields two molecules of formaldehyde. Without hydrolysis, the biocide would have a concentration of 10 mg.l⁻¹. This means that the formaldehyde concentration after complete hydrolysis of the original biocide will be $2 * 30 / 240 * 10 = 2.5 \text{ mg.l}^{-1}$.

The emission scenarios are presented in tables, with the input and output data, and calculations specified. USES units are used in the emission scenarios. The input and output data are divided into four groups:

- S data Set a value for this parameter must be present in the data entry set (data either to be supplied by the notifier or available in the literature);
- D Default a fixed value which can be changed by the user;
- O Output the value being the result of a previous calculation;
- P Pick list parameter values to be chosen from a pick list with values.

For preservatives used for the preservation of pulp in the paper machine no new emission scenario is presented but the basic slimicide scenarios can be used with some specific assumptions. The emission scenarios for slimicides are not directly suited for this kind of applications due to differences such as the lower frequency of application and much higher concentrations. The subject is discussed in Chapter 5. It should be noted that biocidal products used in pulp preservation belong to product-type 9 (Fibres, leather, rubber and polymerised materials preservatives). Furthermore, in the Technical Guidance Document on Risk Assessment (EC, 2002) another emission scenario is available for biocides used in paper coatings and finishing which belong to product types 6, 7 and 9 (in-can, film and fibre preservatives used in the treatment of paper). That scenario includes also paper additives such as filler (e.g. calcium carbonate) and starch slurries are also preserved with biocides. Furthermore, raw water is also treated with biocides but their emissions are not covered by this scenario document.

2 Biocides and active ingredients

Table 2.1 presents an overview of the biocides and active ingredients (a.i.) admitted in the Netherlands (CTB, 1998a) and in Finland (Lindell, 2000). In the Netherlands, about 57 biocidal products have been registered with 17 different a.i., of which some are used in combination with each other. Usually, the content of a.i. in the biocide preparation is specified as g.l¹ as most biocides consist of (aqueous) solutions. For 11 preparations the content is expressed as % by weight. In Finland, about 75 slimicides have been authorised with 19 different a.i.

Table 2.1 Biocide formulations and (types of) active ingredients admitted in the Netherlands as a slimicide for the process water in pulp- and paper industry (CTB, 1998a) and in Finland as a slimicide for the process water in pulp and paper industry and for cooling water use (Lindell, 2000).

Type of active ingredients (a.i.)	No. of biocide formulations		No. of a.i. ¹⁾	
	NL	FIN	NL	FIN
Organic bromine compounds	11	17	2	2
Organic bromine/chlorine compounds	11	6	3	1
Organic chlorine/sulphur compounds	14	13	3	4
Organic sulphur compounds	5	12	3	4
Other organic compounds	7	19	4	4
Inorganic compounds (including bromide)	6	2	1	1
Inorganic compounds (chlorine containing)	3	6	4	3
	57	75	17 ¹⁾	19 ¹⁾

¹⁾Some a.i. are used in combination with each other

3 Dosage and concentration of the biocide

User's instructions for the biocidal products admitted in the Netherlands and in Finland specify dosages in one of the following ways:

[A] Dosage (as an amount by weight or volume) per tonne of paper/cardboard,

[B] Dosage (as an amount by weight or volume) per m³ of water,
and sometimes:

[C] Concentration to be established in the water.

Often ranges for the dosage are given and in many cases for starting dosages for infected systems and maintenance dosages. Addition of the biocide takes usually place at the wire part of the paper machine. The contribution of wastewater from the paper machine to the total wastewater stream of a paper mill depends on the closure of the system. In the Finnish scenarios a contribution of 60% was used (Sirikka, 2001). New results from the survey carried out in Finland show that the dilution and biocide addition parameters are more complex than assumed in these scenarios (Sirikka, 2001).

Typical points of biocide application in the paper making process are wire pit and shower waters in the short circulation of the w&e-end and white water tanks, and broke and pulp storage which belong to the long circulation (Fig. 3.1). Short circulation is the system in which paper machine wire water is separated from the pulp stock in web forming and used for dilution of the thick stock to be delivered to the headbox. Long circulation is the system in which excess process water (white water) from the short circulation and other waters are collected at the paper machine and used for stock dilution and other purposes in stock preparation (Weise *et al.*, 2000). In addition, paper additives (slurries) may also be preserved, raw water treated and the paper coated or preserved with a biocide but they are not covered by this report. In terms of biocide addition, the worst case situation is a machine with biocide addition at several points in the long circulation as well. So, it may be assumed that no dilution occurs with the long circulation water, as in many cases biocides are also added to the long circulation water or to the broke system (Sirikka, 2001). This means that 100% of the water coming from the paper machine – both from the short and long circulation water – has been treated with a biocide. In addition, the average number of paper making machines per mill in Finland is about three (Sirikka, 2001). Because of the fact that the dosage of biocides in these machines is independent of each other, it should be considered that all machines have the biocide added simultaneously as the worst case. Therefore, it has been assumed that 100% of the water is treated with the slimicide by default. This is denoted in the model also as F_{ww1} , i.e. the fraction of the total wastewater flow coming from the short circulation of the wire part.

Slimicide is degraded to some extent already in the process water. On the basis of results from the Finnish paper mill survey the minimum water holding time in the process was 1 - 3 hours for every paper grade, median of all 69 machines was 8 hours and the average 15 hours (Sirikka, 2001).

Therefore, the default process water holding time of 4 hours is used. Hydrolysis during this period is taken into account in the Finnish model and also some biodegradation. This is because although the process water temperature is typically 40-50 °C in the short circulation of paper making process it normally decreases to 30-40 °C before the wastewater treatment plant. Detailed calculations for degradation in process water are presented in Chapter 4.

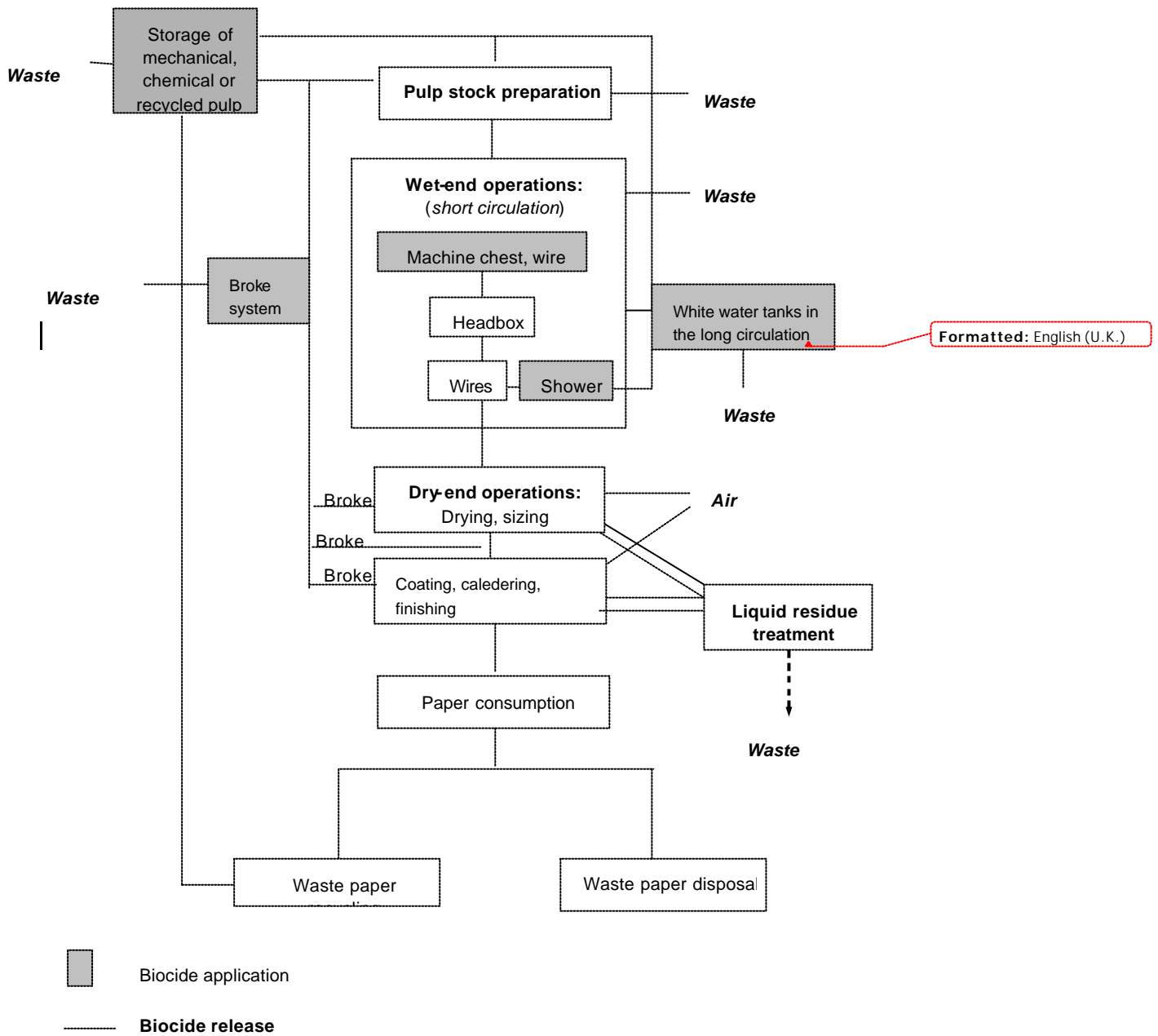

Figure 3.1: Biocide application and releases during paper making.

Many Finnish paper mills have been integrated with pulp mills – twenty out of the 24 interviewed – and these are likely to have biocide-free dilution from pulping wastewater to the biocide containing paper machine wastewater; at present this dilution is assumed to be 40-50%. On account of this, the fraction for dilution F_{ww2} has been introduced in the model. By default no connection to a pulp mill is assumed, i.e. $F_{ww2} = 0\%$; if connection to a pulp mill is considered, F_{ww2} has the default of 50%. The addition of the biocide may take place continuously, with frequent intervals or by an intermittent shock (defouling) treatment. Defouling treatment is typically done once or twice a year with very high slimicide concentrations (e.g. 200-500 ppm) which will not level off much in the STPs. The PECs for such a case should be calculated with a scenario for intermittent emissions. Also in the case of dosing with frequent intervals concentration peaks will occur, which may cause peak concentrations in the wastewater stream as some of the freshly dosed water may be released from the short circulation almost directly. Such peaks will be levelled off when the wastewater reaches primary settler with a longer residence time. However, it should be noted that the maximum concentration in the effluent would be lower than the initial concentration at discharge when the discharge period is shorter than the retention time of the aeration tank (4). This is due to peak dispersion, dilution, and sorption in the sewer system, the primary settler, and the activated sludge process. It is estimated that this maximum concentration will be at least a factor three lower than the initial concentration. Whether or not this correction factor must be applied needs to be decided on a case-by-case basis. For such short emission periods care must be taken that the emission rates or concentrations [A], [B] or [C] are calculated over the actual emission period and not averaged out over one day. It is assumed here that the wastewater coming to the primary settler during the addition of the slimicide is at once completely mixed with the water already present in the basin. The two Finnish scenarios cover the situations [A] and [B/C].

For both [A] and [B] the contents of the a.i. may be specified as $g.l^{-1}$ or as % by weight. For the calculation according to A, the amount of wastewater per tonne of paper/cardboard must be known. For the Dutch situation this amount is estimated to amount 15 - 20 m^3 for paper and 0 - 15 m^3 for massive cardboard, as in Luttik, *et al.* (1993). In the calculations 15 m^3 is used, which means a production of $3000 / 15 = 200$ tonnes of paper/cardboard per day. These values are used for the existing model.

According to Sirkka (2001) an average amount of 15.9 m^3 wastewater per tonne of paper/cardboard has been calculated from the data for 69 Finnish machines. So, for the first scenario ([A]) the default value of 15 m^3 per tonne is also used.

The common part of the models for the calculation of the theoretical concentration of a slimicide (i.e. assuming that no degradation occurs) before wastewater treatment is presented in Table 3.1.

Table 3.1. Common part of the models for the calculation of the theoretical average concentration (i.e. assuming that no degradation occurs) before wastewater treatment, depending on the way the dosage is expressed in the user's instructions. Concentration reduction due to degradation in process water is presented in Chapter 4.

Variable/parameter (unit)	Symbol	Default	S/D/O/P
Input:			
[A]			
Amount of biocide prescribed in user's instructions (unit ¹⁾)	Q _{prod_uins}		S
Amount of wastewater for one tonne of dry paper (m ³):	WW	20	D
[B]			
Amount of biocide prescribed in user's instructions (unit ¹).m ⁻³)		Q _{prod_uins}	S
[A/B]			
Content of active ingredient in biocide preparation (l ¹)	CONTENT		S
Specific density of biocide (kg.m ⁻³)	RHO _{prod}	1,000	D
[B/C]			
Treatment of both long and short circulation with slimicide (-)	APPL	yes	P
Fraction of the total wastewater flow coming from the short circulation of the wire part (%):	F _{ww1}		
- APPL = yes		100	O
- APPL = no		60	D
Connection to pulp mill (-)	CONN	no	P
Fraction dilution of wastewater with wastewater from pulping (%)	F _{ww2}		
- CONN = no		0	O
- CONN = yes		50	D
[C]			
Concentration prescribed in the user's instructions ([A] & [B]) (l ¹)	C _{prescribed}		S

¹⁾ See calculations

Table 3.1. Common part of the models for the calculation of the theoretical average concentration (i.e. assuming that no degradation occurs) before wastewater treatment, depending on the way the dosage is expressed in the user's instructions. Concentration reduction due to degradation in process water is presented in Chapter 4 (continued).

Calculations

[A/B]

Dose (g) of a.i., dependent on specifications for the amount of biocide preparation ($Q_{\text{prod_uins}}$) and content of a.i. in biocide preparation (CONTENT)

	Units: $Q_{\text{prod_uins}}$	CONTENT	
$\text{DOSE}_{\text{ai}} = Q_{\text{prod_uins}} * \text{CONTENT} * 10$	kg	%	(1)
$\text{DOSE}_{\text{ai}} = Q_{\text{prod_uins}} * \text{CONTENT} * 10^3 / \text{RH}_{\text{Oprod}}$	kg	g/l	(2)
$\text{DOSE}_{\text{ai}} = Q_{\text{prod_uins}} * \text{CONTENT} * 10^{-2}$	g	%	(3)
$\text{DOSE}_{\text{ai}} = Q_{\text{prod_uins}} * \text{CONTENT} / \text{RH}_{\text{Oprod}}$	g	g/l	(4)
$\text{DOSE}_{\text{ai}} = Q_{\text{prod_uins}} * \text{CONTENT}$	l	g/l	(5)
$\text{DOSE}_{\text{ai}} = Q_{\text{prod_uins}} * \text{CONTENT} * 10^{-3}$	ml	g/l	(6)

$$[\text{A}] \quad C_{\text{paper}} = \text{DOSE}_{\text{ai}} / \text{WW} \quad (7)$$

$$[\text{B}] \quad C_{\text{paper}} = \text{DOSE}_{\text{ai}} * F_{\text{ww1}} * 0.01 * (1 - F_{\text{ww2}} / 100) \quad (8)$$

$$[\text{C}] \quad C_{\text{paper}} = C_{\text{prescribed}} * F_{\text{ww1}} * 0.01 * (1 - F_{\text{ww2}} / 100) \quad (9)$$

4 Model for the Finnish scenarios

The Finnish scenarios consider the degradation during the process in the paper mill and during the successive wastewater treatment practices (e.g. FEI, 1999; Sirkka, 2001). The first scenario deals with the situation that the user's instructions specify the dosage per tonne of dry paper and the second the processes with frequent treatment of the water at the wire part of the paper machine. In both cases the wastewater first goes to a primary settling unit, followed by three possible ways of treatment. First, the wastewater may be treated in an STP with activated sludge and a secondary settler. Second, there may only be chemical/mechanical treatment. Third, there may be biological treatment with a long retention time. After treatment the effluent is discharged to surface water.

The following types of degradation are taken into account at the successive stages involved (if applicable):

I PAPER MAKING PROCESS

Biodegradation and degradation due to hydrolysis

II PRIMARY SETTLING

Biodegradation and degradation due to hydrolysis

TREATMENT:

IIIa STP (Activated sludge)

Biodegradation and degradation due to hydrolysis

IIIb Secondary settling

Biodegradation and degradation due to hydrolysis

IV CHEMICAL/MECHANICAL

Biodegradation and degradation due to hydrolysis

V LONG-TERM BIOLOGICAL

Biodegradation and degradation due to hydrolysis and photolysis

Remarks:

1. It should be noted that the biodegradation and photolysis rates as established in laboratory testing already include the hydrolysis rate, as the effect of water molecules on the degradation of substances can not be prevented; hydrolysis occurs parallel to the biodegradation and photolysis processes. It is assumed that photolysis is not included in the laboratory testing for hydrolysis and biodegradation.
2. The paper making process may take place at acid circumstances, i.e. a pH value of about 5, at neutral circumstances (pH=7) or at slightly alkaline circumstances, i.e. a pH value of about 8). As the pH may have a significant influence on the half-life times (DT50), the calculation should be carried out with the longest realistic DT50. According to the international test guidelines for hydrolysis the notifier should specify three DT50s, one for acid conditions, one for the neutral situation and one for alkaline conditions.
A sensitivity analysis carried out shows that only for easily degrading substances the pH may have a significant effect; otherwise, it does not have any influence on the calculated PEC (Sirkka, 2001). So, if no data for the DT50s at acid and alkaline conditions are provided by the notifier, the DT50s for pH=7 are used (leading to equal PEC values for all pH values for the process).

Only in the case that the notifier states that the slimicide only should be used at a certain pH the corresponding DT50 should be used.

For biodegradation a distinction has to be made between "normal" biodegradation as takes place in water other than in an STP and in an STP with STP-micro-organisms.

Removal of slimicides because of volatilisation from the water has not been considered yet. In principle volatilisation may be calculated with a fugacity model or a default value of 10% could be used. Emission of the slimicide to the air due to volatilisation of process water at the drying process has not been considered either in this report; according to confidential data this route may be considered to be insignificant (Braunschweiler, 1993a).

3. For the wastewater treatment with activated sludge or another biological treatment system the risk for micro-organisms has to be assessed. The average concentration is calculated at the middle of the retention time of the treatment, assuming homogeneous mixing in the aeration tank c.q. basin. Adsorption to sludge in the STP has not been considered either. As a conservative estimate the Finnish scenarios assume that the DT50 for biodegradation in an STP is half the DT50 for water.
4. The Finnish scenarios assume that photolysis only occurs during the day, half the retention time is used for the photolysis calculation.
5. In the Netherlands in some cases the wastewater from paper mills is treated in an anaerobic reactor before treatment in an aerobic installation. In Finland one of the respondents reported to operate an anaerobic reactor (Sirikka, 2001). This situation is not considered (realistic worst case).
6. At higher temperatures hydrolysis and biodegradation can be assumed to elapse faster according to the Arrhenius equation:

$$k = A * e^{(-E_a/R*T)}$$

where k is the rate constant considered, A is a constant, E_a is the activation energy, R is the universal gas constant and T is the temperature in Kelvin.

The Finnish survey shows that the process water of the 69 respondents has a temperature between 30 and 40 °C in roughly 25% of the cases, a temperature between 40 and 50 °C in 55% of the cases and temperatures above 55 °C in the remainder of the cases. Temperature of wastewater was on average 38 °C varying between 23 and 50 °C among the 26 treatment plants. In order to determine the rate constant at different temperatures, the activation energy E_a must be known to calculate the so-called Arrhenius constant A. In the case that several half-life times are known, the rate constant at any temperature can be established. At present, this has not been worked out for the model (worst case situation). It should be noted that correction for the highest occurring process water temperatures is only of interest in specific situations (site specific). As quite often several slimicides will be compared at the same time – i.e. hazard ranking – the worst case approach will suffice normally. However, a temperature correction may be carried out according to the Arrhenius and van 't Hoff equations as described in e.g. Van den Berg and Boesten (1998): $DT50_{T2} = DT50_{T1} * e^{(0.08 * (T1 - T2))}$ where T1 is the laboratory temperature in the degradation test and T2 is the process temperature.

Figure 4.2 gives the scheme of the possible stage of the water flow, together with the time periods for each stage and the points where PECs have to be calculated. See Table 4.2 for values of these parameters.

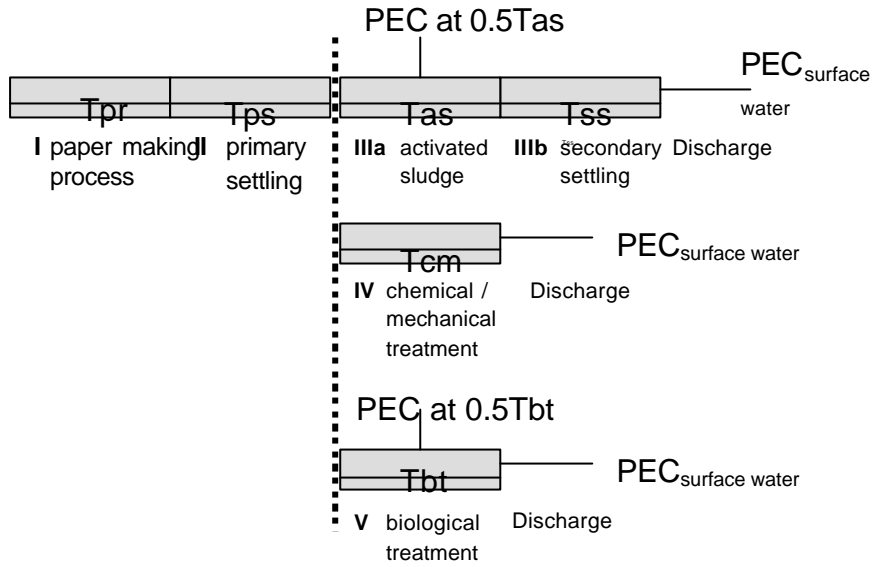

Figure 4.2 Scheme of the water flow depending on the type of wastewater treatment with the time periods and points where PECs have to be calculated (see Table 4.2 for values of these parameters).

Rate constants for degradation

For both scenarios the same calculations for the rate constants for degradation have to be carried out. So, this part of the model is presented here in Table 4.1.

Table 4.1 Common part for the emission scenarios for calculating the release of slimicides in paper mills taking biodegradation and degradation due to hydrolysis and photolysis into account

Variable/parameter (unit)	Symbol	Default	S/D/O/P
Input:			
Half-life time for hydrolysis in acid circumstances	DT50hydr _{acid}		S
Half-life time for hydrolysis in neutral circumstances	DT50hydr _{water} ¹⁾		S
Half-life time for hydrolysis in alkaline circumstances	DT50hydr _{alkal}		S
Half-life time for photolysis in water	DT50photo _{water}		S
Half-life time for biodegradation for activated sludge	DT50bio _{stp} ²⁾	DT50bio _{water} /2	D
[I] Biodegradation test 12 hours light/12 hours dark			
Half-life time for biodegradation in water	DT50bioI _{water}		S
[II] Biodegradation test in the dark			
Half-life time for biodegradation in water	DT50bioII _{water}		S
Output:			
khydr _{acid}	=	rate constant for degradation due to hydrolysis at acid (pH~5) conditions (d ⁻¹)	
khydr _{water}	=	rate constant for degradation due to hydrolysis at neutral (pH~7) conditions (d ⁻¹)	
khydr _{alkal}	=	rate constant for degradation due to hydrolysis at alkaline (pH~8) conditions (d ⁻¹)	
kbiotot _{water}	=	rate constant for biodegradation in water including hydrolysis (d ⁻¹) and photolysis (d ⁻¹) ³⁾	
kbio _{water}	=	rate constant for biodegradation in water (d ⁻¹)	
kbioh _{water}	=	rate constant for biodegradation in water including hydrolysis (d ⁻¹)	
kbiotot _{stp}	=	rate constant for biodegradation in STPs including hydrolysis (d ⁻¹)	
kphototot _{water}	=	rate constant for photolysis including hydrolysis (d ⁻¹)	
kphoto _{water}	=	rate constant for photolysis (d ⁻¹)	

Table 4.1 Common part for the emission scenarios for calculating the release of slimicides in paper mills taking biodegradation and degradation due to hydrolysis and photolysis into account (continued)

Model calculations:

$$k_{hydr_{acid}} = \ln 2 / DT50_{hydr_{acid}} \quad (10)$$

$$k_{hydr_{water}} = \ln 2 / DT50_{hydr_{water}} \quad (11)$$

$$k_{hydr_{alkal}} = \ln 2 / DT50_{hydr_{alkal}} \quad (12)$$

$$k_{phototot_{water}} = \ln 2 / DT50_{photo_{water}} \quad (13)$$

$$k_{photo_{water}} = k_{phototot_{water}} - k_{hydr_{water}} \quad (14)$$

$$k_{biotot_{stp}} = \ln 2 / DT50_{bio_{stp}} \quad (15)$$

[I]

$$k_{biotot_{water}} = \ln 2 / DT50_{bioI_{water}} \quad (16)$$

$$k_{bioh_{water}} = k_{biotot_{water}} - k_{photo_{water}} \quad (17)$$

$$k_{bio_{water}} = k_{biotot_{water}} - k_{hydr_{water}} \quad (18)$$

[II]

$$k_{bioh_{water}} = \ln 2 / DT50_{bioII_{water}} \quad (19)$$

$$k_{bio_{water}} = k_{bioh_{water}} - k_{hydr_{water}} \quad (20)$$

$$k_{biotot_{water}} = k_{bioh_{water}} + k_{photo_{water}} \quad (21)$$

¹⁾ This symbol is already used in EUSES.

²⁾ Depending on the availability of DT50_{bioI_{water}} or DT50_{bioII_{water}}.

³⁾ EUBEES II: photolysis is added. It is believed that this parameter includes photolysis and is not the same as k_{bioh_{water}}.

⁴⁾ EUBEES II: Equation 17 is believed to have an error. It probably should be k_{bioh_{water}} = k_{biotot_{water}} - k_{photo_{water}}.

New paper mill model
Model description:

The model utilises the theoretical concentration calculated according to Table 3.1, C_{paper}, as the input value. Therefore, this input for the calculations in the model scenario presented here is stated as "O". This means that it is output from a previous calculation.

For the default input values of the other parameters estimates based on Braunschweiler (1993b) and Sirkka (2001) have been used. Table 4.2 presents the model together with the default input values.

Table 4.2 Model for the calculation of the relevant PECs depending on the user's instructions: [A] amount of biocide per tonne of product and [B/C] amount of biocide per m³ of water at the wire part of the paper machine.

Variable/parameter (unit)	Symbol	Default	S/D/O/P
Input:			
Theoretical concentration of a.i.	C _{paper}		O
Retention time for paper making process (h)	T _{prh}	4	D
Retention time for primary settling (h)	T _{ps_h}	4	D
Retention time for the activated sludge unit (h)	T _{as_h}	4	D
Retention time for secondary settling (h)	T _{ss_h}	4	D
Retention time for chemical/mechanical treatment (h)	T _{cm_h}	4	D
Retention time for long-term biological treatment (h)	T _{bt_h}	40	D
Dilution factor at discharge surface water	DILUTION _{paper}	10 ¹⁾	D

¹⁾ Default value of USES

Output:

PEC _{ASstp_acid}	= Predicted environmental concentration for assessment of micro-organisms in STP with activated sludge for acid conditions at the paper making process
PEC _{ASstp_neutr}	= Predicted environmental concentration for assessment of micro-organisms in STP with activated sludge for neutral conditions at the paper making process
PEC _{ASstp_alkal}	= Predicted environmental concentration for assessment of micro-organisms in STP with activated sludge for alkaline conditions at the paper making process
PEC _{BTstp_acid}	= Predicted environmental concentration for assessment of micro-organisms in STP with a long-term biological treatment for acid conditions at the paper making process
PEC _{BTstp_neutr}	= Predicted environmental concentration for assessment of micro-organisms in STP with a long-term biological treatment for neutral conditions at the paper making process
PEC _{BTstp_alkal}	= Predicted environmental concentration for assessment of micro-organisms in STP with a long-term biological treatment for alkaline conditions at the paper making process
PEC _{localAS_water_acid}	= Predicted Environmental Concentration in receiving surface water after activated sludge treatment for acid process conditions at paper making
PEC _{localAS_water_neutr}	= Predicted Environmental Concentration in receiving surface water after activated sludge treatment for neutral process conditions at paper making

Table 4.2 Model for the calculation of the relevant PECs depending on the user's instructions: [A] amount of biocide per tonne of product and [B/C] amount of biocide per m³ of water at the wire part of the paper machine.

PEC _{local} _{AS_water_alkal}	= Predicted Environmental Concentration in receiving surface water after activated sludge treatment for alkaline process conditions at paper making
PEC _{local} _{CM_water_acid}	= Predicted Environmental Concentration in receiving surface water after chemical/mechanical treatment for acid process conditions at paper making
PEC _{local} _{CM_water_neutr}	= Predicted Environmental Concentration in receiving surface water after chemical/mechanical treatment for neutral process conditions at paper making
PEC _{local} _{CM_water_alkal}	= Predicted Environmental Concentration in receiving surface water after chemical/mechanical treatment for alkaline process conditions at paper making
PEC _{local} _{BT_water_acid}	= Predicted Environmental Concentration in receiving surface water after long-term biological treatment for acid process conditions at paper making
PEC _{local} _{BT_water_neutr}	= Predicted Environmental Concentration in receiving surface water after long-term biological treatment for neutral process conditions at paper making
PEC _{local} _{BT_water_alkal}	= Predicted Environmental Concentration in receiving surface water after long-term biological treatment for alkaline process conditions at paper making

Intermediate calculations

Retention times (d) for paper making process, primary settling, activated sludge treatment, secondary settling, chemical/mechanical treatment and long-term biological treatment respectively:

$$T_{pr} = T_{pr_h} / 24 \quad (18)$$

$$T_{ps} = T_{ps_h} / 24 \quad (19)$$

$$T_{as} = T_{as_h} / 24 \quad (20)$$

$$T_{ss} = T_{ss_h} / 24 \quad (21)$$

$$T_{cm} = T_{cm_h} / 24 \quad (22)$$

$$T_{bt} = T_{bt_h} / 24 \quad (23)$$

Table 4.2 Model for the calculation of the relevant PECs depending on the user's instructions: [A] amount of biocide per tonne of product and [B/C] amount of biocide per m³ of water at the wire part of the paper machine (continued).

Concentrations after primary settling for acid, neutral and alkaline process conditions respectively (mg.l⁻¹):

$$C_{acid} = C_{paper} * e^{-\{(k_{bio_water} + k_{hyd}_{acid}) * T_{pr} + k_{biotot_water} * T_{ps}\}} \quad (I/II.1)$$

$$C_{neutr} = C_{paper} * e^{-k_{biotot_water} * (T_{pr} + T_{ps})} \quad (I/II.2)$$

$$C_{alkal} = C_{paper} * e^{-\{(k_{bio_water} + k_{hyd}_{alkal}) * T_{pr} + k_{biotot_water} * T_{ps}\}} \quad (I/II.3)$$

Concentrations after secondary settling in the case of activated sludge treatment (mg.l⁻¹)

$$C_{acid_AS} = C_{acid} * e^{-\{k_{biotot_stp} * T_{as} + k_{biotot_water} * T_{ss}\}} \quad (III.1)$$

$$C_{neutr_AS} = C_{neutr} * e^{-\{k_{biotot_stp} * T_{as} + k_{biotot_water} * T_{ss}\}} \quad (III.2)$$

$$C_{alkal_AS} = C_{alkal} * e^{-\{k_{biotot_stp} * T_{as} + k_{biotot_water} * T_{ss}\}} \quad (III.3)$$

Concentrations after chemical/mechanical treatment (mg.l⁻¹):

$$C_{acid_CM} = C_{acid} * e^{-k_{biotot_water} * T_{cm}} \quad (IV.1)$$

$$C_{neutr_CM} = C_{neutr} * e^{-k_{biotot_water} * T_{cm}} \quad (IV.2)$$

$$C_{alkal_CM} = C_{alkal} * e^{-k_{biotot_water} * T_{cm}} \quad (IV.3)$$

Concentrations after long-term biological treatment (mg.l⁻¹):

$$C_{acid_BT} = C_{acid} * e^{-T_{bt} * (k_{biotot_water} + 0.5k_{photo_water})} \quad (V.1)$$

$$C_{neutr_BT} = C_{neutr} * e^{-T_{bt} * (k_{biotot_water} + 0.5k_{photo_water})} \quad (V.2)$$

$$C_{alkal_BT} = C_{alkal} * e^{-T_{bt} * (k_{biotot_water} + 0.5k_{photo_water})} \quad (V.3)$$

End calculations

PEC in aeration tank at activated sludge treatment for acid, neutral and alkaline process conditions respectively (mg/l):

$$PEC_{ASstp_acid} = C_{acid} * e^{-0.5 * k_{biotot_stp} * T_{as}} \quad (III.4)$$

$$PEC_{ASstp_neutr} = C_{neutr} * e^{-0.5 * k_{biotot_stp} * T_{as}} \quad (III.5)$$

$$PEC_{ASstp_alkal} = C_{alkal} * e^{-0.5 * k_{biotot_stp} * T_{as}} \quad (III.6)$$

PEC in aeration basin at long-term biological treatment for acid, neutral and alkaline process conditions respectively (mg/l):

$$PEC_{BTstp_acid} = C_{acid} * e^{-0.5 * T_{bt} * (k_{biotot_water} + 0.5k_{photo_water})} \quad (V.4)$$

$$PEC_{BTstp_neutr} = C_{neutr} * e^{-0.5 * T_{bt} * (k_{biotot_water} + 0.5k_{photo_water})} \quad (V.5)$$

$$PEC_{BTstp_alkal} = C_{alkal} * e^{-0.5 * T_{bt} * (k_{biotot_water} + 0.5k_{photo_water})} \quad (V.6)$$

PEC in receiving surface water after activated sludge treatment for acid, neutral and alkaline process conditions respectively (mg/l):

$$PEC_{local_AS_water_acid} = C_{acid_AS} * DILUTION_{paper}^1 \quad (III.7)$$

$$PEC_{local_AS_water_neutr} = C_{neutr_AS} * DILUTION_{paper} \quad (III.8)$$

$$PEC_{local_AS_water_alkal} = C_{alkal_AS} * DILUTION_{paper} \quad (III.9)$$

Table 4.2 Model for the calculation of the relevant PECs depending on the user's instructions: [A] amount of biocide per tonne of product and [B/C] amount of biocide per m³ of water at the wire part of the paper machine (continued).

PEC in receiving surface water after chemical/mechanical treatment for acid, neutral and alkaline process conditions respectively (mg/l):

$$PEC_{local_CM_water_acid} = C_{acid_CM} * DILUTION_{paper} \quad (IV.4)$$

$$PEC_{local_CM_water_neutr} = C_{neutr_CM} * DILUTION_{paper} \quad (IV.5)$$

$$PEC_{local_CM_water_basic} = C_{alkal_CM} * DILUTION_{paper} \quad (IV.6)$$

PEC in receiving surface water after long-term biological treatment for acid, neutral and alkaline process conditions respectively (mg/l):

$$PEC_{local_BT_water_acid} = C_{acid_BT} * DILUTION_{paper} \quad (V.7)$$

$$PEC_{local_BT_water_neutr} = C_{neutr_BT} * DILUTION_{paper} \quad (V.8)$$

$$PEC_{local_BT_water_alkal} = C_{alkal_BT} * DILUTION_{paper} \quad (V.9)$$

^{*)} EUBEES II: Equation III.7 up to V.9 should have /DILUTION instead of *DILUTION

It should be noted that this approach for calculation of PECs also may be used in other emission scenarios for other product-types.

CHARM-scenario

Drilling chemicals

As explained in Section 2.2, the calculation rules in the CHARM model for drilling chemicals only address Water Base Mud (WMB). The discharge of WMBs can be continuous or batchwise. Only chemicals not appearing in the OSPAR PLONOR list (formerly PARCOM List A), a list of chemicals and products that are natural constituents of seawater or natural products such as nutshells and clays (OLF, 1993) are considered. PLONOR-listed substances are those whose discharge from offshore installations does not need to be strongly regulated as, from experience of their discharge, the OSPUR commission considers that they Pose Little Or NO Risk to the environment.

In most cases, the concentration of a mud-additive in the water column is dependent upon the amount of additive present in the mud, the amount of mud discharged and its partition and degradation characteristics in sea water.

Both continuous and the batchwise discharges have to be taken into account. Although the highest concentrations are caused by batchwise discharges, both pathways will be assessed in the CHARM model. The higher of the two PEC:PNEC ratios will be regarded as the worst case for the additive.

The amount of a certain additive present in the mud-system (further referred to as dosage) can be expressed as a weight percentage or as a concentration (the common unit being pounds per barrel: ppb). The first step in the calculation is, therefore, to use this dosage together with the volume of mud discharged (either continuous or batchwise) to calculate the amount of additive discharged (Equations 12 and 13). Consequently, when performing calculations on batchwise discharges, one will first multiply the dosage with V_m to obtain the mass of additive discharged (M) and subsequently divide it by the same V_m to obtain the concentration of additive in the mud. This step is necessary to yield a value for M with the correct metrics (kg), which is used for the calculation of PEC for continuous discharges. It must be noted that different mud volumes apply for batchwise and continuous discharges.

To derive the regional water concentration of an additive within continuously discharged mud, the amount of additive discharged is divided by the volume of water (during the period of discharge) in which is diluted. To take into account that other platforms in the area might also contribute to the regional concentration of a chemical, the water available for dilution is limited to the fixed area per platform defined by the standard platform density of one platform per 10 square kilometres (Equation 14). This dilution is enhanced by the residual current, which leads to refreshment of the water in the area (Equation 15).

The dilution characteristics of batchwise discharges differ significantly from those of continuous discharges, due to the increased discharge rates (i.e., $1.56 \text{ m}^3 \cdot \text{hr}^{-1}$ and $135 \text{ m}^3 \cdot \text{h}^{-1}$ for continuous and batchwise discharges respectively – from: CIN Expert Group on Drilling Chemicals, 1998). A different calculation is, therefore, required in each case.

Box 2a: Calculation of PEC_{water} for Continuous WBM discharges

For continuous discharges, the mass of a non-PLONOR additive in a WBM which is discharged can be calculated using one of the following equations, dependent upon the expression of dosage:

Dosage expressed as weight percentage:

$$M \text{ Wt } V_m * P_m \quad (12)$$

in which:

M = amount (mass) of non-PLONOR-listed additive discharged (kg)

Wt = weight percentage of the non-PLONOR-listed additive in the mud (%)

V_m = volume of mud discharged for the specific section (m³)

ρ_m = density of the discharged mud (kg.m⁻³)

Dosage expressed as pounds per barrel (ppb):

$$M \times V \text{ ppb} * V_m * 2.85 \quad (13)$$

in which:

M = amount (mass) of non PLONOR-listed additive discharged (kg)

X_{ppb} = dosage of the non PLONOR-listed additive in the mud (pounds per barrel)

V_m = volume of mud discharged for the specific section (m³)

2.85 = conversion constant from ppb to kg.m⁻³

Volume of ambient water available as diluent

$$V_p = (1/\text{platf density}) * \text{waterdepth} * 10^6 \quad (14)$$

in which:

V_p = volume of ambient water per platform (m³)

platf.density = number of platforms per square kilometre (km⁻²)

water depth = average water depth around the platform (m)

10⁶ = factor used to convert km² to m² (m².km⁻²)

Refreshment rate of the ambient water

$$r = (24 \cdot 3600) / (2 \cdot Y / U) \quad (15)$$

in which:

- r = fraction of sea water refreshed in the receiving volume around the platform per day (day⁻¹)
- Y = radius from platform corresponding to the area of ambient water available as diluent (i.e. $p \cdot Y^2 = 1 / \text{Platform density} \cdot 106$) (m)
- U = residual current speed (m.s⁻¹)
- 3600 = factor used to convert hours to seconds (s.h⁻¹)
- 24 = factor used to convert days to hours (h.d⁻¹)
- 2 = factor used to convert radius from platform to diameter of the area

The volume of water passing the platform during the period of drilling a section:

$$V_t = V_p \cdot r \quad (16)$$

in which:

- V_t = volume of water passing the platform (m³.d⁻¹)
- V_p = volume of ambient water per platform (m³)
- r = fraction of sea water refreshed in the area around the platform per day (d⁻¹)

PEC_{water} for **continuous** discharges of non-PLONOR additives in WBM can now be calculated using:

$$PEC_{\text{water, cont}} = (M / T \cdot V_t) \cdot 10^3 \quad (17)$$

in which:

- PEC_{water, cont} = PEC_{water} for continuous discharges (mg.l⁻¹)
- M = amount (mass) of non PLONOR-listed additive discharged (kg)
- T = time needed to drill a section (d)
- V_t = volume of water passing the platform (m³.d⁻¹)
- 103 = conversion constant to express PEC as mg.l⁻¹

Box 2b: Calculation of PECwater for Batchwise discharges

PECwater for **batchwise** discharges of non-PLONOR additives in WBM can be calculated using:

$$PEC_{waterbatch} = M/V * D_{batch} * 10^3$$

in which:

$PEC_{water, batch}$ = PECwater for batchwise discharges ($mg.l^{-1}$)

M = amount (mass) of non PLONOR-listed additive discharged (kg)

V_m = volume of mud discharged for the specific section (m^3)

D_{batch} = dilution factor for batchwise discharges

103 = conversion constant to express PEC as $mg.l^{-1}$

Drilling chemicals

Calculation of HQwater

PECwater

Since drilling chemicals are the additives to drilling fluids (within CHARM these fluids are limited to water based muds), the actual dosage of the additive in the mud is the basis for the calculations. Although the dosage may be different in the various sections of the well, the CHARM calculations are calculated for a single section only. The subsequent calculation steps are described below.

1. Before the calculations can be performed, the chemical use (HOCNF 1.3) of the additive has to be expressed in kg. Since this is not the standard unit used for additives, the reported dosage might have to be converted. If the dosage is expressed as a weight percentage of the total mud, this can be done using Equation 12. The dosage could also be expressed as pounds per barrel (ppb), in which case the dosage can be converted using Equation 13. If dosage is expressed in another unit, the user has to find their own equation to convert the dosage into kg.
2. The actual calculation of the PEC is now dependent on the type of discharge. If the discharge is continuous, the calculation of the PEC is described in step 3 and if the discharge is batchwise, the calculation of the PEC is described in step 4.
3. For continuous discharges, the PEC is calculated using Equation 17 in which both discharge time (T) and the volume of water passing the platform per unit of time (Vt) are incorporated.
4. With batchwise discharges, the PEC is calculated using Equation 18, which makes use of the volume of mud discharged and the dilution factor for batchwise discharges.

Table: Default values for calculating the PEC for drilling chemicals (both continuous and batchwise discharge)

Parameter	Value	Unit
-----------	-------	------

Platform density at 1784	0.1	km ⁻²
Drilling time per section	16	days
Water depth	150	m
Refreshment rate	0.24	d ⁻¹
Batchwise dilution factor	7.7 10 ⁻⁵ (1:13,000)	-

Table: Default data related to the drilling of the various sections

Section drilled	Length drilled (m)	Mud density discharge (kg.m ⁻³)	Volume continuous discharge (m ³)	Volume batchwise (m ³)
36"	100	-	*	-
24"	400	-	*	-
17½"	1500	1400	600	-
12,5½"	1500	1600	450	375
8,5½"	1000	1600	250	280

Only OSPAR PLONOR-listed chemicals are used in the drilling of the 36" and 24" sections

Appendix 2: Calculation results

Calculations RIVM/FEI-scenarios

Common part of wastewater treatment: primary settling

$$C = C_{\text{paper}} * e^{-k_{\text{biotot}}_{\text{water}} * (T_{\text{pr}} + T_{\text{ps}})}$$

$$\text{Substance 1: } C = 0.01 \text{ kg/m}^3 * e^{-0 * 1/3} = 0.01 \text{ kg/m}^3$$

$$\text{Substance 2: } C = 0.01 \text{ kg/m}^3 * e^{-0 * 1/3} = 0.01 \text{ kg/m}^3$$

$$\text{Substance 3: } C_{\text{pH5}} = 0.01 \text{ kg/m}^3 * e^{-1.93 * 1/3} = 0.00526 \text{ kg/m}^3$$

$$\text{Substance 3: } C_{\text{pH7}} = 0.01 \text{ kg/m}^3 * e^{-6.40 * 1/3} = 0.00118 \text{ kg/m}^3$$

$$\text{Substance 3: } C_{\text{pH9}} = 0.01 \text{ kg/m}^3 * e^{-11.39 * 1/3} = 0.000224 \text{ kg/m}^3$$

Paper mill with treatment in an short-term activated sludge unit (16 hours total retention time)

$$\text{PEC}_{\text{local AS_water}} = C * e^{-(k_{\text{biotot}}_{\text{stp}} * T_{\text{as}} + k_{\text{biotot}}_{\text{water}} * T_{\text{ss}})} / \text{DILUTION}_{\text{paper}}$$

$$\text{Substance 1: } \text{PEC}_{\text{local AS_water}} = 0.01 * e^{-(0 * 1/6 + 0 * 1/6)} / 10 = 0.001 \text{ kg/m}^3$$

$$\text{Substance 2: } \text{PEC}_{\text{local AS_water}} = 0.01 * e^{-(2.4 * 1/6 + 0 * 1/6)} / 10 = 0.00067 \text{ kg/m}^3$$

$$\text{Substance 3: } \text{PEC}_{\text{local AS_water_pH5}} = 0.00526 * e^{-((2.4 + 1.93) * 1/6 + 1.93 * 1/6)} / 10 = 0.000185 \text{ kg/m}^3$$

$$\text{Substance 3: } \text{PEC}_{\text{local AS_water_pH7}} = 0.00118 * e^{-((2.4 + 6.40) * 1/6 + 6.40 * 1/6)} / 10 = 0.00000937 \text{ kg/m}^3$$

$$\text{Substance 3: } \text{PEC}_{\text{local AS_water_pH9}} = 0.000224 * e^{-((2.4 + 11.39) * 1/6 + 11.39 * 1/6)} / 10 = 0.000000337 \text{ kg/m}^3$$

Paper mill with chemical/mechanical wastewater treatment (8 hours total retention time)

$$\text{PEC}_{\text{local CM_water}} = C * e^{-(k_{\text{biotot}}_{\text{water}} * T_{\text{cm}})} / \text{DILUTION}_{\text{paper}}$$

$$\text{Substance 1: } \text{PEC}_{\text{local CM_water}} = 0.01 * e^{-(0 * 1/6)} / 10 = 0.001 \text{ kg/m}^3$$

$$\text{Substance 2: } \text{PEC}_{\text{local CM_water}} = 0.01 * e^{-(0 * 1/6)} / 10 = 0.001 \text{ kg/m}^3$$

$$\text{Substance 3: } \text{PEC}_{\text{local CM_water_pH5}} = 0.00526 * e^{-(1.93 * 1/6)} / 10 = 0.000381 \text{ kg/m}^3$$

$$\text{Substance 3: } \text{PEC}_{\text{local CM_water_pH7}} = 0.00118 * e^{-(6.40 * 1/6)} / 10 = 0.0000406 \text{ kg/m}^3$$

$$\text{Substance 3: } \text{PEC}_{\text{local CM_water_pH9}} = 0.000224 * e^{-(11.39 * 1/6)} / 10 = 0.00000336 \text{ kg/m}^3$$

Paper mill with long term biological treatment (2 days total retention time) ¹⁾

$$\text{PEC}_{\text{local BT_water}} = C * e^{-T_{\text{bt}} * (k_{\text{biotot}}_{\text{water}} + 0.5 k_{\text{photo}}_{\text{water}})} / \text{DILUTION}_{\text{paper}}$$

$$\text{Substance 1: } \text{PEC}_{\text{local BT_water}} = 0.01 * e^{-(1/2/3 * 0)} / 10 = 0.001 \text{ kg/m}^3$$

$$\text{Substance 2: } \text{PEC}_{\text{local BT_water}} = 0.01 * e^{-((5/6 * 2.40 * 5/6 * 0 + 1/2/3 * 0)} / 10 = 1.35 \cdot 10^{-4} \text{ kg/m}^3$$

$$\text{Substance 3: } \text{PEC}_{\text{local BT_water_pH5}} = 0.00526 * e^{-((5/6 * (2.4+1.93) + 5/6 * 1.93 + 1/2/3 * 0)} / 10 = 0.00000285 \text{ kg/m}^3$$

$$\text{Substance 3: } \text{PEC}_{\text{local BT_water_pH7}} = 0.00118 * e^{-((5/6 * (2.4+6.40) + 5/6 * 6.40 + 1/2/3 * 0)} / 10 = 3.72 \cdot 10^{-10} \text{ kg/m}^3$$

$$\text{Substance 3: } \text{PEC}_{\text{local BT_water_pH9}} = 0.000224 * e^{-((5/6 * (2.4+11.39) + 5/6 * 11.39 + 1/2/3 * 0)} / 10 = 1.73 \cdot 10^{-14} \text{ kg/m}^3$$

1) Half of T_{bt} corresponds with an activated sludge system. Therefore a separation is made between the period that biological degradation takes place and the period that both biological degradation and hydrolysis takes place (5/6 and 5/6 instead of 1 2/3).

Calculations USES -scenarios

$$PECl_{\text{ocal water}} = (C_{\text{paper}} * F_{\text{STP}}) / \text{DILUTION}_{\text{paper}}$$

Substance 1:

$$PECl_{\text{ocal water}} = (0.01 * F_{\text{STPwater}}) / 10 = (0.01 * 0.846) / 10 = 0.00085 \text{ kg/m}^3$$

$$PECl_{\text{ocal sludge}} = (0.01 * F_{\text{STPwater}}) / 10 = (0.01 * 0.129) / 10 = 0.000013 \text{ kg/m}^3$$

$$PECl_{\text{ocal air}} = (0.01 * F_{\text{STPair}}) / 10 = (0.01 * 0.025) / 10 = 0.000025 \text{ kg/m}^3$$

Substance 2:

$$PECl_{\text{ocal water}} = (0.01 * F_{\text{STPwater}}) / 10 = (0.01 * 0.592) / 10 = 0.00059 \text{ kg/m}^3$$

$$PECl_{\text{ocal sludge}} \text{ and } PECl_{\text{ocal air}} = 0 \text{ kg/m}^3$$

Substance 3:

$$PECl_{\text{ocal water}} = (0.01 * F_{\text{STPwater}}) / 10 = (0.01 * 0.509) / 10 = 0.00051 \text{ kg/m}^3$$

$$PECl_{\text{ocal sludge}} = (0.01 * F_{\text{STPwater}}) / 10 = (0.01 * 0.146) / 10 = 0.00015 \text{ kg/m}^3$$

$$PECl_{\text{ocal air}} = 0 \text{ kg/m}^3$$